







Fitting for 2 symmetrically opening glass doors up to 80 kg (176 lbs.), with surface mounted running track or running track flush with the ceiling. Ceiling mounting.

Product highlights

-  **Flexibility** Door openings up to 2280 mm (7'5 3/4 ")
-  **Aesthetics** Symmetrical solution without guide track possible

Technical specifications

-  Max. 80 kg (176 lbs.)
-  Max. 3000 mm (9'10 1/8")
-  500–1200 mm (1'7 11/16" to 3'11 1/4")
-  8–16 mm (5/16" to 5/8")

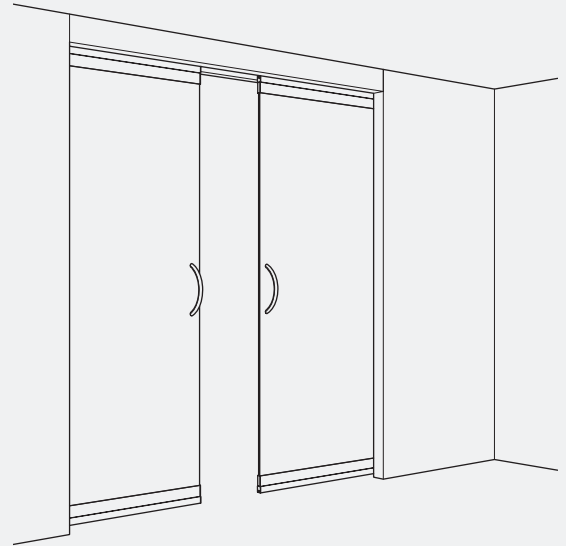

Installation examples

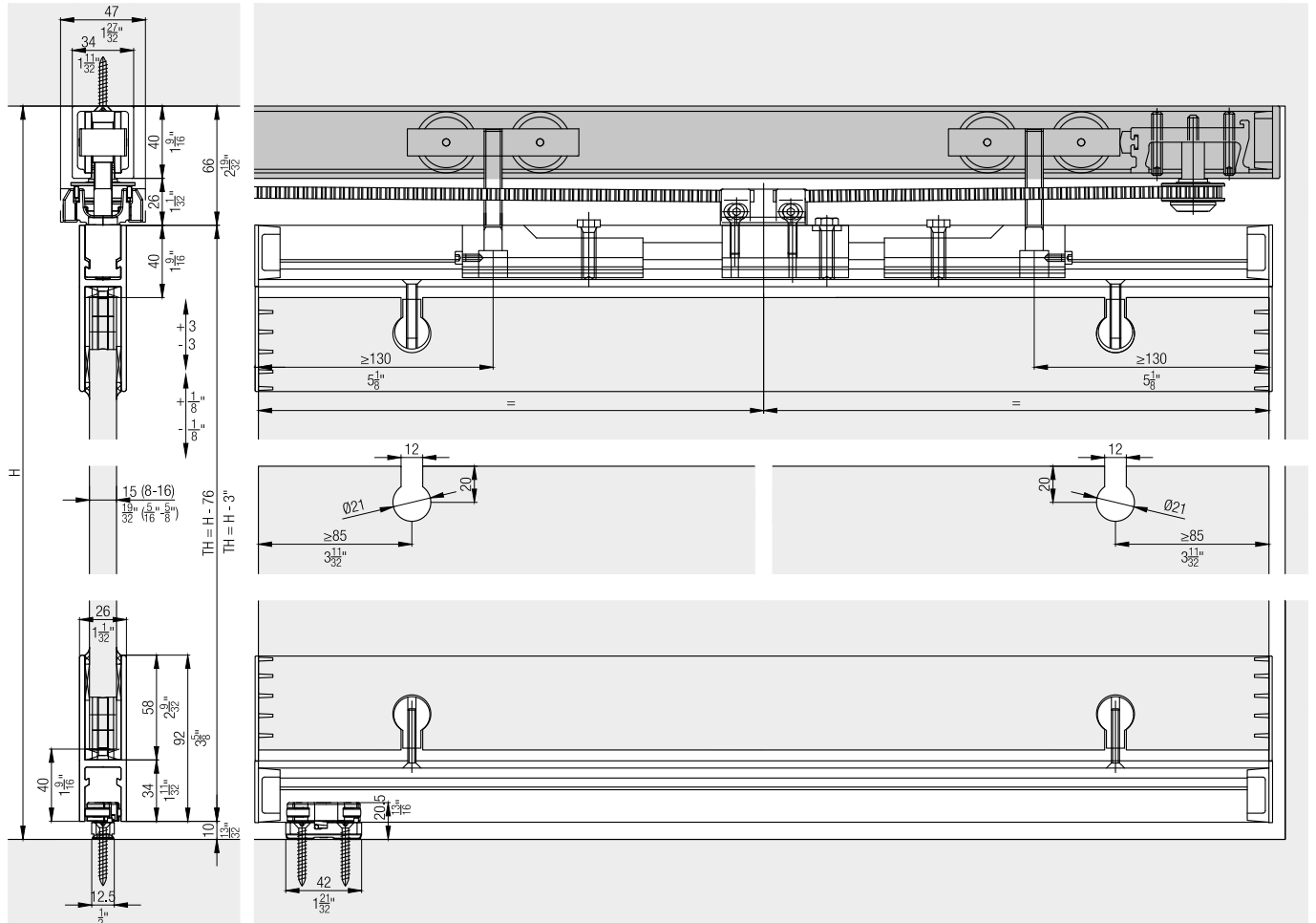



Set for 2 glass door up to 80 kg (176 lbs.)

	No.
Hawa Junior 80 G Symmetric, for 2 doors	14557

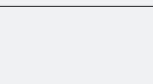
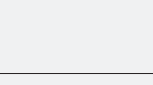

Set consisting of:

		14557	No.
	Running gear, 2-wheeled, M10, plastic wheels	4	10407
	Suspension plate, with suspension bolt M10	4	14543
	Stopper Hawa Junior 80/100, with adjustable retention spring	1	30138
	Pulley wheel Hawa Junior Symmetric/Telescopic	2	15788
	Clamp for toothed belt	2	15790
	Toothed belt 10 m (32' 9 11/16")	1	15712
	Cover cap for glass suspension profile, plastic, anthracite	4	20907
	Screw-on rubber door stop	2	10629
	Locking wrench to suspension	1	10778

Suspension and glass retaining profiles

		mm (inch)	No.
	Glass suspension/retainer profile, aluminum, anodized, brushed, glass up to 8-16 mm (5/16"-5/8")	6,500 (21' 3 29/32")	21783
	cut to size		21784
	Glass suspension/retainer profile, aluminum, glass up to 16 mm (5/8")	6,500 (21' 3 29/32")	13158
	cut to size		13159
	Glass suspension/retainer profile, aluminum, anodized, brushed, glass up to 8-10 mm (5/16"-13/32")	6,500 (21' 3 29/32")	21781
	cut to size		21782
	Glass suspension/retainer profile, aluminum, glass up to 10 mm (13/32")	6,500 (21' 3 29/32")	10348
	cut to size		10349
	Multi purpose suspension and retainer profile, aluminum, anodized, undrilled	6,500 (21' 3 29/32")	10345
	cut to size		12915

Cover caps



		No.
	Cover cap for glass suspension/retainer profile 21783/21784/13158/13159, glass up to 16 mm (5/8"), plastic, anthracite	21085
	Cover cap for glass suspension/retainer profile 21781/21782/10348/10349, glass up to 10 mm (13/32"), plastic, anthracite	21512

Glass holder

Order 2 pieces per suspension and glass retaining profile

		No.
	Glass holder insert, plastic, with countersunk head screw, M6x30 mm (1/4"x1 3/16")	10792

Bottom guides

		No.
	Rattle-proof mounted guide, with wheels	24905
	Connecting bolt for bottom guide track, 6x40 mm (1/4"x1 9/16"), steel, zinc-plated	13759



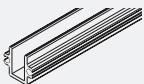

Running tracks

		mm (inch)	No.
	Running track, aluminum, anodized, pre-drilled	2,000 (6' 6 3/4 ")	10192
		2,200 (7' 2 5/8 ")	10193
		2,500 (8' 2 7/16")	10194
		3,000 (9' 10 1/8 ")	18532
		4,000 (13' 1 15/32")	18533
		6,000 (19' 8 7/32")	10186
		cut to size	10188

Guide tracks

		mm (inch)	No.
	Guide track, aluminum, anodized, pre-drilled	6,000 (19' 8 7/32")	13688
		cut to size	13690

Accessories

		No.
	Cover cap to running track, both sides, steel, chrome-plated, matt	24956
	Cover cap for glass suspension profile, plastic, anthracite	20907
	Bottom door stopper, with centering, stainless steel look	21473
	Bottom door stopper, with centering, chrome-plated, matt	20773
	Guide, rattle proof, with suspension block, plastic, 14 mm (9/16")	13781

Installation examples bottom guides

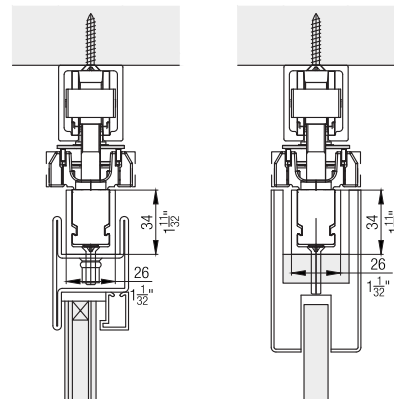

Individual solution

The suspension profile (12915) allows for the use of commercial as well as customer-specific suspension and glass retaining profiles.

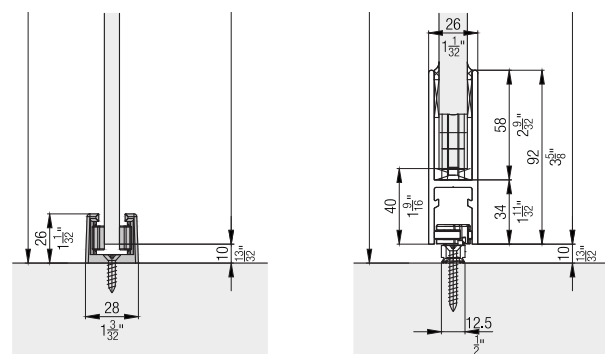

Accessories

- Lock solutions from page 479
- General accessories from page 487
- Glass recommendations from page 504

Planning/execution

Further information about the product can be found on www.hawa.com.