

DE Vorderansicht  
FR Vue de face  
EN Front view  
IT Vista frontale  
ES Vista frontal

DE Ablängen der Profile  
FR Raccourcir les profilés  
EN Cutting the profiles to length  
IT Taglio a misura dei profili  
ES Cortar a medida los perfiles

DE Seitenansicht  
FR Vue de côté  
EN Side view  
IT Vista laterale  
ES Vista lateral

DE Draufsicht  
FR Vue de dessus  
EN Top view  
IT Vista dall'alto  
ES Vista superior

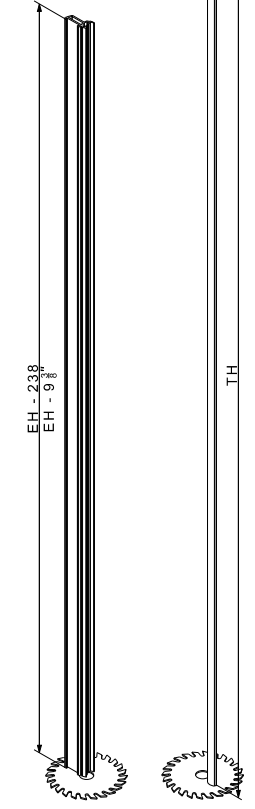
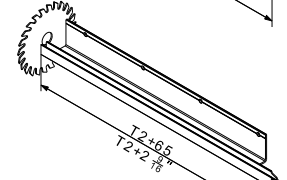
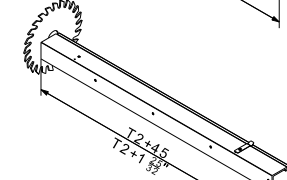
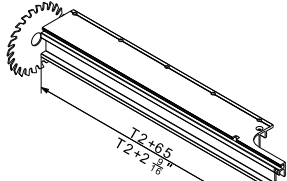
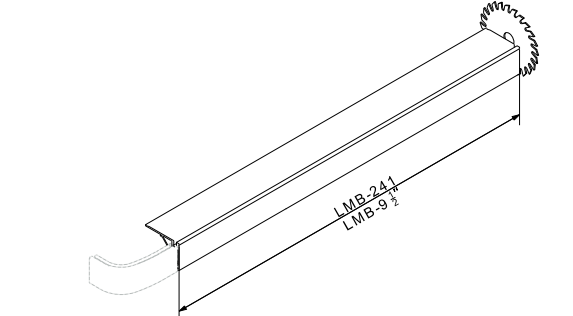
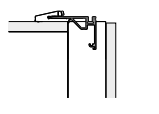
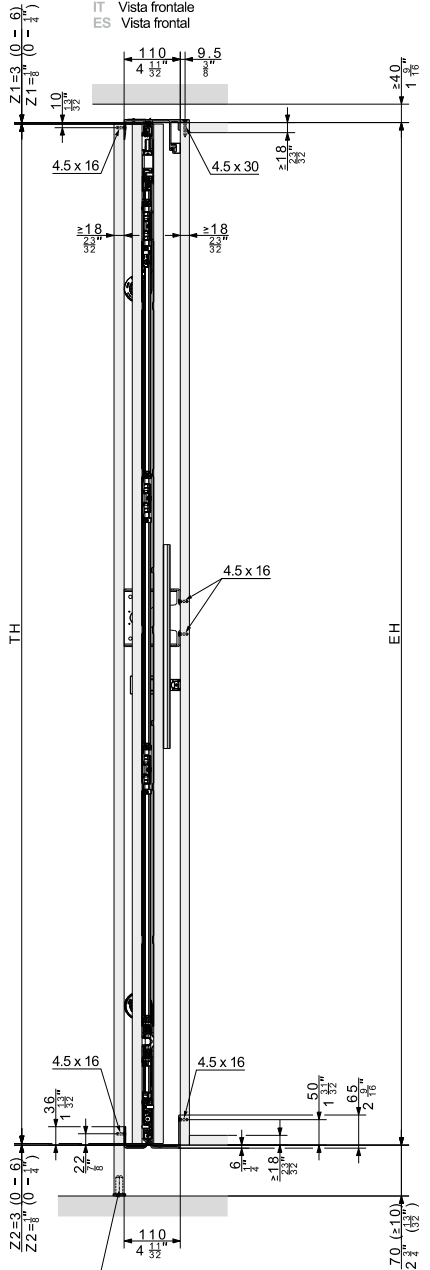

DE ohne Möbelboden  
FR Sans fond  
EN without base panel  
IT senza fondo del mobile  
ES sin base

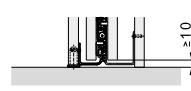

DE mit Bodenprofil, siehe Beipackblatt 52036  
FR Avec profil de fond inférieur, voir le mode d'emploi joint 52036  
EN with base profile, see leaflet 52036  
IT con profilo a pavimento, vedere manuale di istruzioni 52036  
ES con perfil para la base: ver hoja de instrucciones 52036

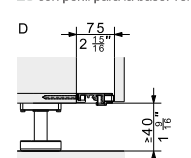

DE Empfehlung: Stelfuss verwenden  
FR Recommendation : utiliser un pied de réglage  
EN Recommendation: Use adjustable foot  
IT Raccomandazione: Utilizzare un piedino regolabile  
ES Recomendación: Utilizar un pie ajustable

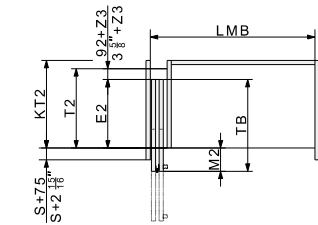
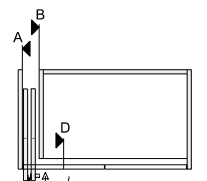
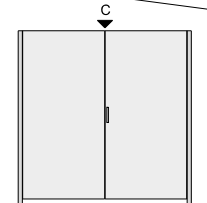

	mm	Inch
T2	TB + 92 + Z3 - M2	TB + 3 5/8" + Z3 - M2
E2	TB - M2	TB - M2
KT2	≥ T2	≥ T2
M2	≥ S + 75 ≤ TB - 390	≥ S + 2 15/16" ≤ TB - 1' 3 11/32"

	mm	Inch
S	18 - 26	3/32" - 1 1/32"
T2	≥ 344	≥ 1' 1 13/32"
TB	440 - 750	1' 5 11/16" - 2' 5 31/32"
TH (III 20)	1200 - 2200	3' 11 1/4" - 7' 2 5/8"
TH (III 25)	1900 - 2700	6' 2 13/16" - 8' 10 5/16"
Z1	0 - 6	0 - 1/4"
Z2	0 - 6	0 - 1/4"
Z3	2 - 5	3/32" - 3/16"
Z4	2 - 5	3/32" - 3/16"
Z5	2 - 5	3/32" - 3/16"

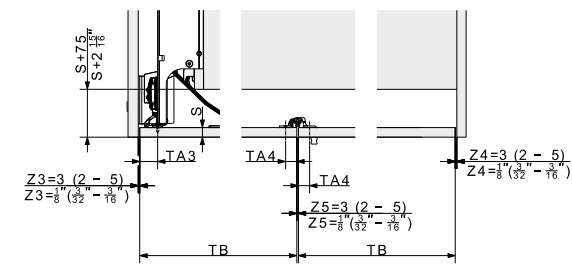
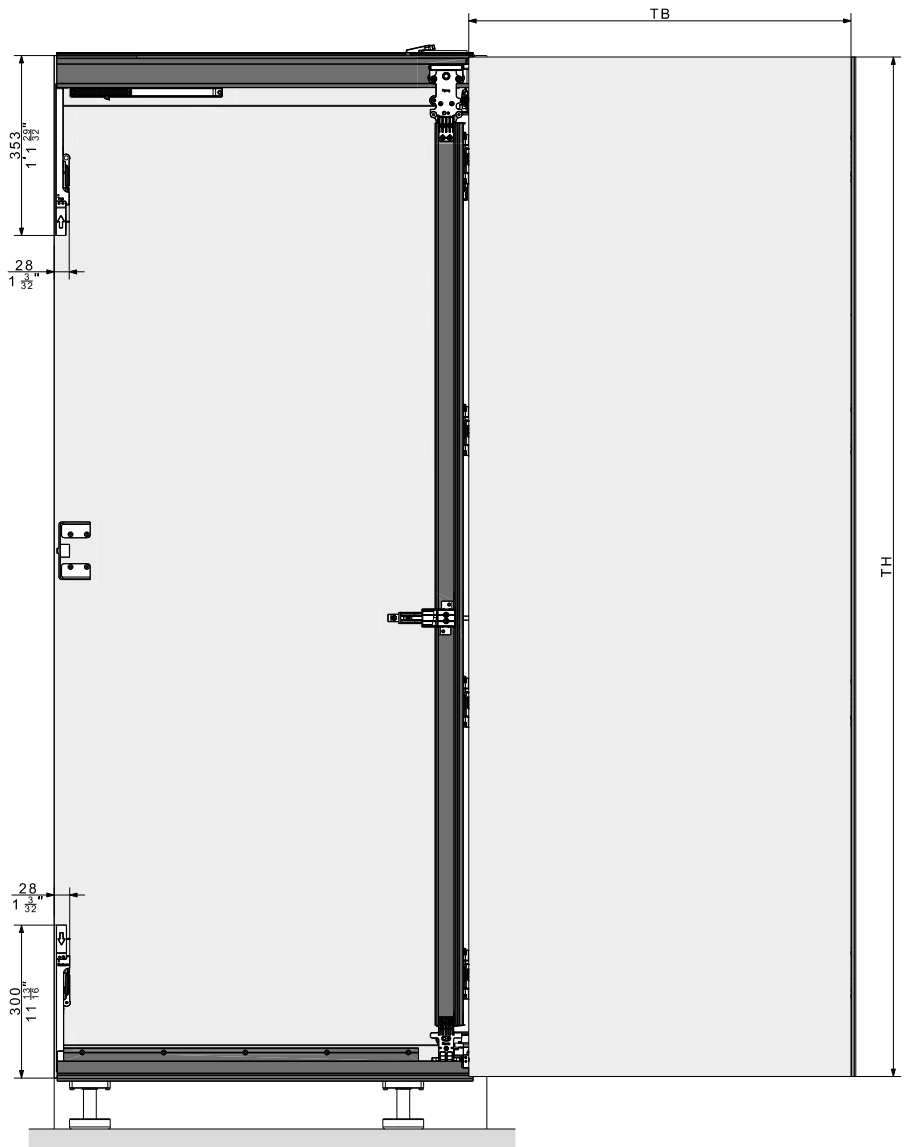

Z3	TA3	Z5	TA4
2 mm (3/32")	29 mm (1 1/8")	2 mm (3/32")	22.5 mm (7/8")
3 mm (1/8")	28 mm (1 1/8")	3 mm (1/8")	22 mm (7/8")
4 mm (5/32")	27 mm (1 1/8")	4 mm (5/32")	21.5 mm (7/8")
5 mm (3/16")	26 mm (1 1/8")	5 mm (3/16")	21 mm (13/16")

DE Türe vorstehend  
FR Porte en saillie  
EN Protruding door  
IT Porta sporgente  
ES Puerta saliente

DE Türe bündig  
FR Porte affleurante  
EN Flush door  
IT Porta complanare  
ES Puerta enrasada

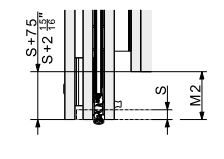
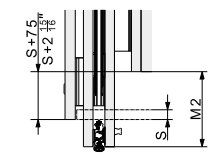

DE Abkürzungen / FR Abréviations / EN Abbreviations / IT Abbreviazioni / ES Abreviaturas

	DE	FR	EN	IT	ES
E2	Einschubtiefe	Profondeur d'escamotage	Slide-in depth	Profondità di inserimento	Profundidad de introducción
EH	Einbauhöhe	Hauteur d'encastrement	Installation height	Altezza d'incasso	Altura de montaje
KT2	Korpustiefe	Profondeur de corps	Cabinet depth	Profondità mobile	Profundidad del mueble
LMB	Lichtmassbreite	Largeur intérieure	Inside clearance	Larghezza luce	Ancho interior
M2	Türüberstand über Korpus	Saillie de la porte par rapport au corps	Door projection over cabinet	Sporgenza anta sopra il mobile	Solape de la puerta sobre el cuerpo
S	Türdicke	Epaisseur de porte	Door thickness	Spessore anta	Grosor de la puerta
T2	Beschlagtiefe	Profondeur de ferrure	Hardware depth	Profondità ferramenta	Profundidad del herraje
TA	Topfachsabstand	Ecartement d'axe de la charnière invisible	Axis-centre distance of concealed hinge	Distanza scatola/asse	Distancia de la cazoleta
TB	Türbreite	Largeur de porte	Door width	Larghezza anta	Ancho de puerta
TH	Türhöhe	Hauteur de porte	Door height	Altezza anta	Altura de puerta
Z	Luftzwischenraum	Jeu dans l'espacement	Air gap	Traferro d'ania	Espacio libre

DE Hawa Folding Concepta III Pull 2-türig links  
FR Hawa Folding Concepta III Pull 2 portes, à gauche  
EN Hawa Folding Concepta III Pull 2 doors, left  
IT Hawa Folding Concepta III Pull 2 ante, a sinistra  
ES Hawa Folding Concepta III Pull 2 puertas izquierda

Hawa Folding Concepta III Pull 2-türig links  
161967 V03 1/2

