

DE Vorderansicht  
FR Vue de face  
EN Front view  
IT Vista frontale  
ES Vista frontal

DE Ablängen der Profile  
FR Raccourcir les profils  
EN Cutting the profiles to length  
IT Taglio a misura dei profili  
ES Cortar a medida los perfiles

Hawa Folding Concepta III 25 Push

DE Seitenansicht  
FR Vue de côté  
EN Side view  
IT Vista laterale  
ES Vista lateral

Hawa Concepta III 35 Push

DE Seitenansicht  
FR Vue de côté  
EN Side view  
IT Vista laterale  
ES Vista lateral

DE Ablängen der Profile  
FR Raccourcir les profils  
EN Cutting the profiles to length  
IT Taglio a misura dei profili  
ES Cortar a medida los perfiles

DE Vorderansicht  
FR Vue de face  
EN Front view  
IT Vista frontale  
ES Vista frontal

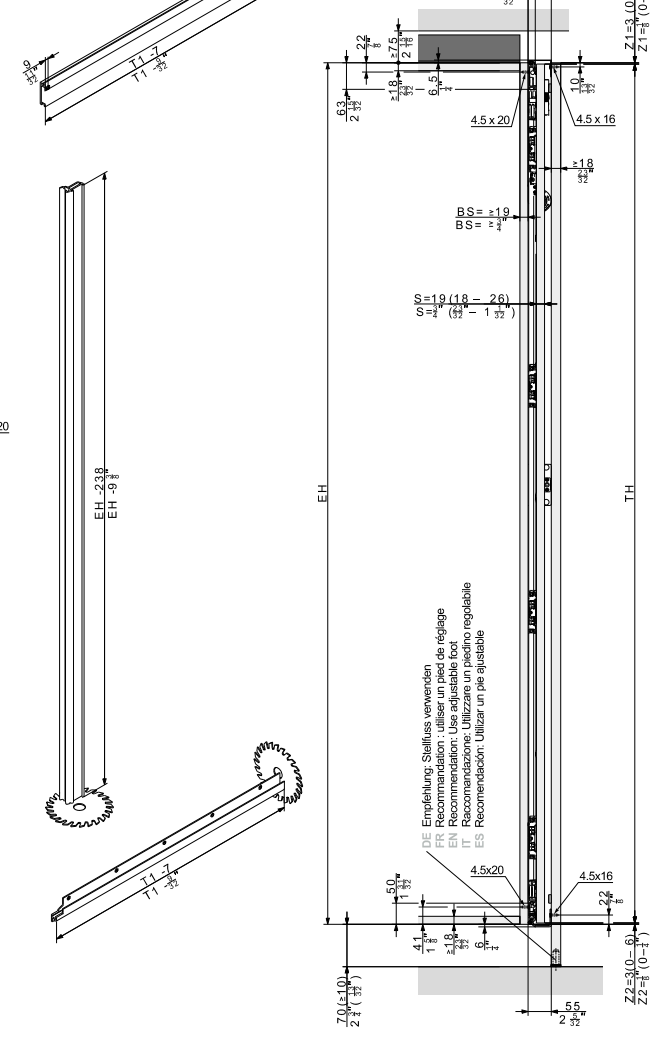
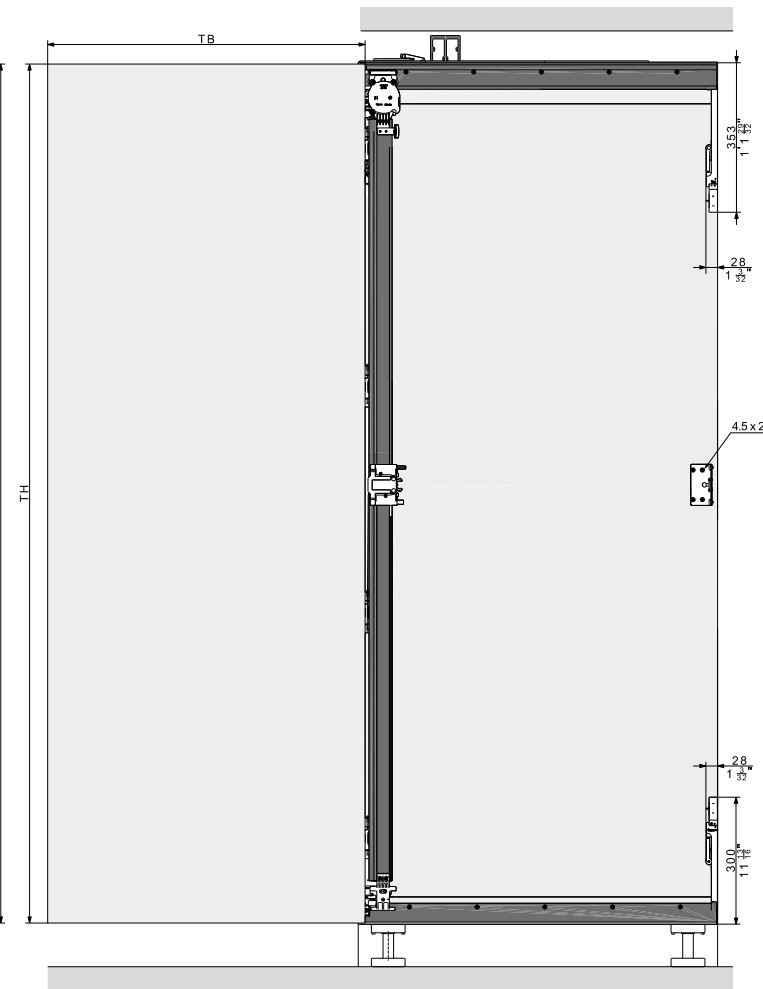
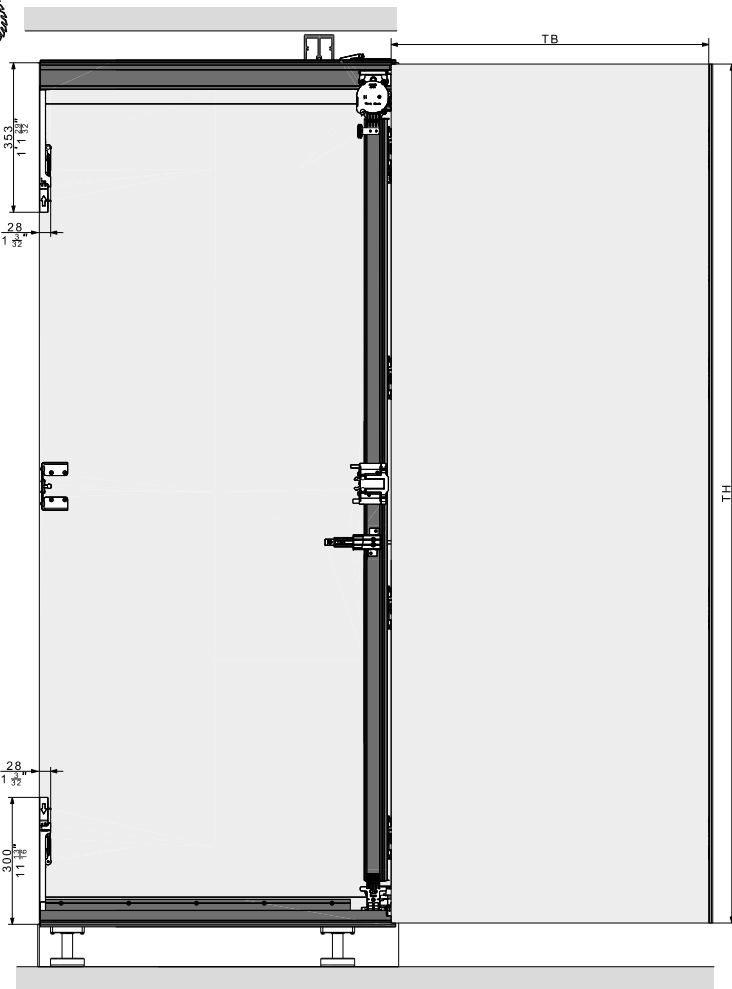
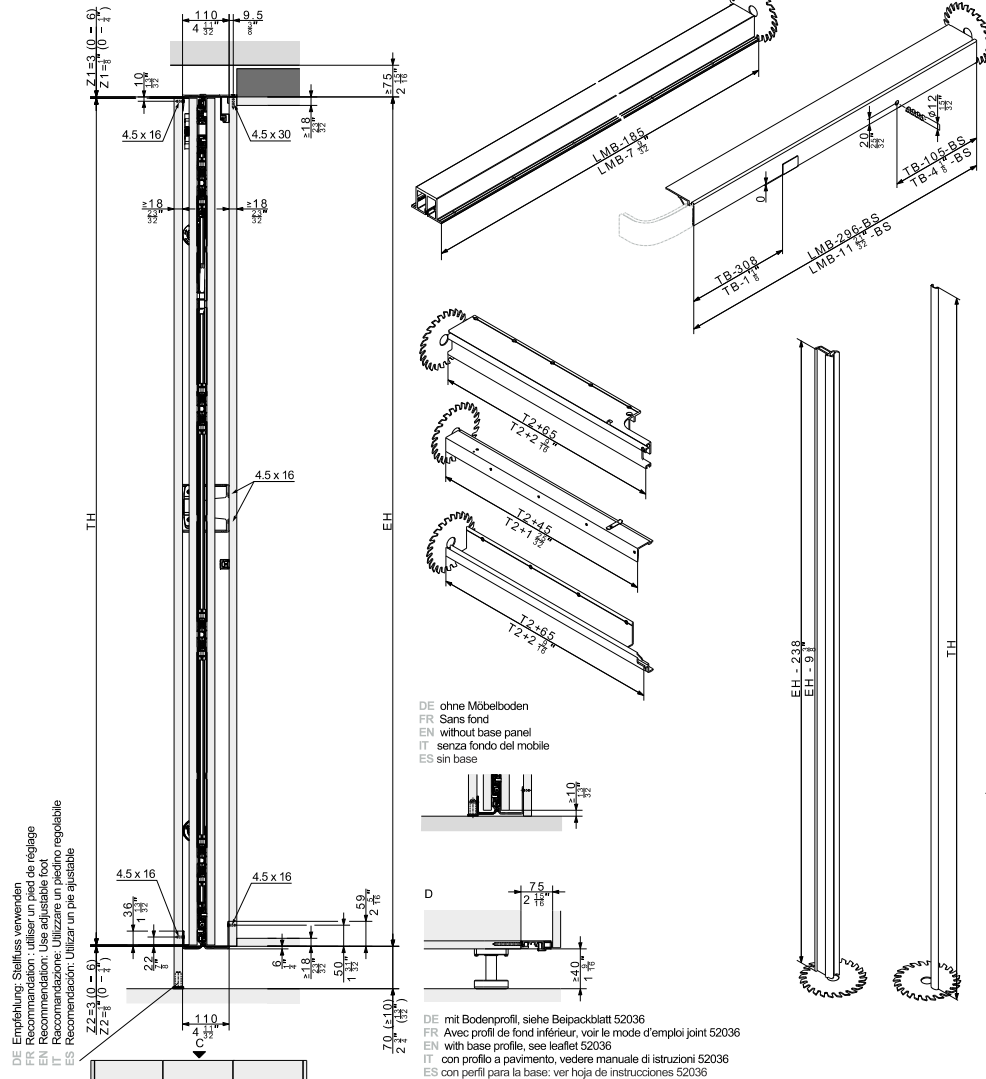

DE ohne Möbelboden  
FR Sans fond  
EN without base panel  
IT senza fondo del mobile  
ES sin base

DE mit Bodenprofil, siehe Beispickblatt 52036  
FR Avec profil de fond inférieur, voir le mode d'emploi joint 52036  
EN with base profile, see leaflet 52036  
IT con profilo a pavimento, vedere manuale di istruzioni 52036  
ES con perfil para la base: ver hoja de instrucciones 52036

DE Verstärkungsprofil  
FR Profil de renforcement  
EN Reinforcement profile  
IT Profilo di rinforzo  
ES Perfil de refuerzo

DE Variante Verstärkungsprofil innliegend  
FR Profil de renforcement Variante à l'intérieur  
EN Variant with inlying reinforcement profile  
IT Variante profilo di rinforzo interno  
ES Versión con perfil de refuerzo en el interior

DE Bei 3-türigen Anlagen ohne Mittelwände zwingend das  
Hawa Verstärkungsprofil 24322 verwenden.  
FR Pour les installations à 3 portes sans parois centrales,  
utiliser obligatoirement le profil de renforcement Hawa 24322.  
EN It is essential to use the Hawa reinforcement profile 24322  
with 3-door systems without separating walls.  
IT In sistemi a 4 ante senza pareti centrali è obbligatorio  
utilizzare il profilo di rinforzo Hawa 24322.  
ES En instalaciones de 4 puertas sin pared central es  
imprescindible utilizar el perfil de refuerzo Hawa 24322.

DE Montage Verstärkungsprofil siehe Beispickblatt 52064  
FR Montage profil de renforcement voir le mode d'emploi joint 52064  
EN Reinforcement profile installation see leaflet 52064  
IT Vedere il montaggio del profilo di rinforzo nel manuale di istruzioni 52064  
ES Montaje del perfil de refuerzo: ver hoja de instrucciones 52064

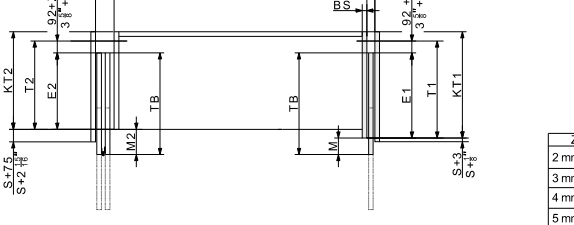
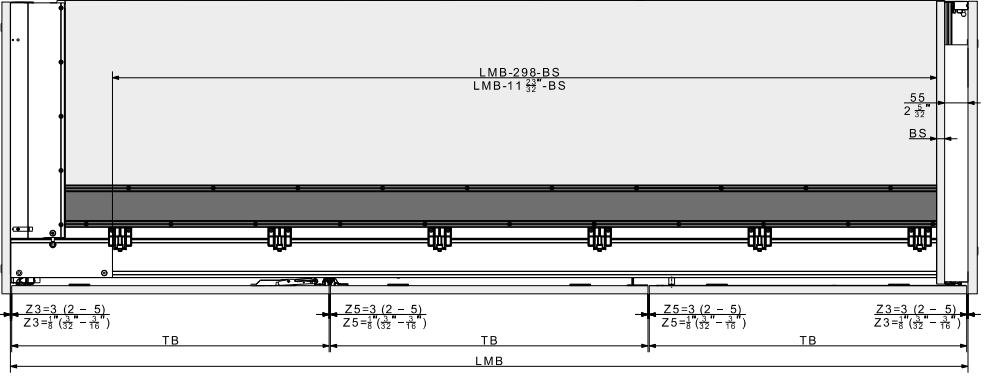

Z3	TA1	Z3	TA3	Z5	TA4
2 mm (3/16")	29 mm (1 1/8")	2 mm (3/16")	29 mm (1 1/8")	2 mm (3/16")	22.5 mm (7/8")
3 mm (1/8")	28 mm (1 1/8")	3 mm (1/8")	28 mm (1 1/8")	3 mm (1/8")	22 mm (7/8")
4 mm (5/16")	27 mm (1 1/8")	4 mm (5/16")	27 mm (1 1/8")	4 mm (5/16")	21.5 mm (7/8")
5 mm (3/8")	26 mm (1 1/8")	5 mm (3/8")	26 mm (1 1/8")	5 mm (3/8")	21 mm (7/8")

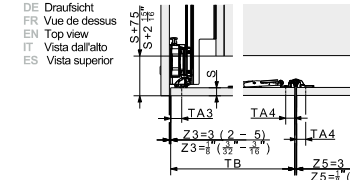

DE Abkürzungen / FR Abréviations / EN Abbreviations / IT Abbreviazioni / ES Abreviaturas

DE	FR	EN	IT	ES
BS Beschlagsvertiefung	Epaisseur du côté extérieur	Fitting side thickness	Spessore lato ferramenta	Grosor del lado del herraje
E Einschubtiefe	Profondeur d'encastement	Slide-in depth	Profondità di inserimento	Profundidad de introducción
EH Einbauhöhe	Hauteur d'encastement	Installation height	Altezza d'incasso	Altura de montaje
KT Korpusstärke	Profondeur de corps	Cabinet depth	Profondità mobile	Profundidad del mueble
LMB Lichtmassbreite	Largeur intérieure	Inside clearance	Larghezza luce	Ancho interior
M Türüberstand über Korpus	Saillie de la porte par rapport au corps	Door projection over cabinet	Sporgenza anta sopra il mobile	Solape de la puerta sobre el cuerpo
S Türdicke	Epaisseur de porte	Door thickness	Spessore anta	Grosor de la puerta
T Beschlagtiefe	Profondeur de ferrure	Hardware depth	Profondità ferramenta	Profundidad del herraje
TA Topfachsabstand	Ecartement d'axe de la chambrée invisible	Axis-centre distance of concealed hinge	Distanza scatola asse	Distanza de la cazoleta
TB Türbreite	Largeur de porte	Door width	Larghezza anta	Ancho de puerta
TH Türhöhe	Hauteur de porte	Door height	Altezza anta	Altura de puerta
Z Luftzwischenraum	Au dans l'espace	Air gap	Traffero d'aria	Espacio libre

DE Draufsicht  
FR Vue de dessus  
EN Top view  
IT Vista dall'alto  
ES Vista superior

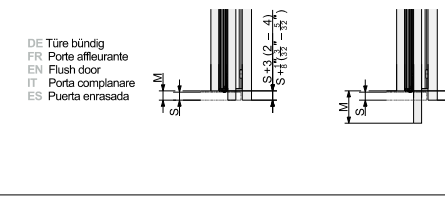
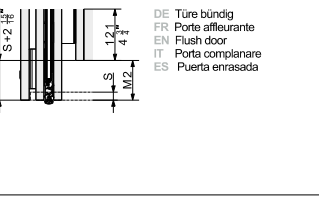
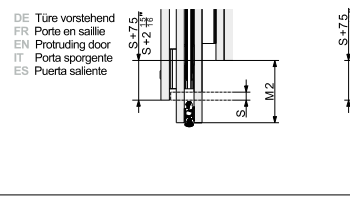

	Hawa Folding Concepta III	Hawa Concepta III
DE Masse FR Dimensions EN Dimensions IT Dimensioni ES Medidas	mm	mm
BS		± 19
S	18 - 26	± 3*
T1		± 344
T2		± 414
TB	440 - 750	
TH	1200 - 2700	
Z1	0 - 6	
Z2	0 - 6	
Z3	2 - 5	
Z5	2 - 5	
DE Formeln FR Formules EN Formulas IT Formule ES Fórmulas	mm	mm
T1	TB + 92 + Z3 - M	TB + 92 + Z3 - M
T2	TB + 92 + Z3 - M2	TB + 92 + Z3 - M2
E1	TB - M	TB - M
E2	TB - M2	TB - M2
KT1		≥ T1
KT2		≥ T2
M	≥ S + 3 ≥ TB - 320	≥ S + 3 ≥ TB - 320
M2	≥ S + 75 ≥ TB - 350	≥ S + 75 ≥ TB - 350

	Hawa Folding Concepta III	Hawa Concepta III
DE Masse FR Dimensions EN Dimensions IT Dimensioni ES Medidas	Inch	Inch
BS		± 3*
S	3/4" - 1 1/8"	± 3*
T1		± 1' 1 1/2"
T2		± 1' 4 1/2"
TB	17 3/8" - 29 1/2"	
TH	3' 11 1/2" - 8' 10 1/8"	
Z1	0 - 1/4"	
Z2	0 - 1/4"	
Z3	3/16" - 3/8"	
Z5	3/16" - 3/8"	
DE Formeln FR Formules EN Formulas IT Formule ES Fórmulas	Inch	Inch
T1	TB + 3 5/8" + Z3 - M	TB + 3 5/8" + Z3 - M
T2	TB + 3 5/8" + Z3 - M2	TB + 3 5/8" + Z3 - M2
E1	TB - M	TB - M
E2	TB - M2	TB - M2
KT1		≥ T1
KT2		≥ T2
M	≥ S + 2 1/8" ≥ TB - 12 1/2"	≥ S + 2 1/8" ≥ TB - 12 1/2"
M2	≥ S + 2 7/8" ≥ TB - 13 3/4"	≥ S + 2 7/8" ≥ TB - 13 3/4"

DE Hawa Folding Concepta III Push links, Hawa Concepta III Push rechts  
FR Hawa Folding Concepta III Push, à gauche, Hawa Concepta III Push, à droite  
EN Hawa Folding Concepta III Push, left, Hawa Concepta III Push, right  
IT Hawa Folding Concepta III Push, a sinistra, Hawa Concepta III Push, a destra  
ES Hawa Folding Concepta III Push izquierda, Hawa Concepta III Push derecha

Hawa Folding Concepta III Push links, Hawa Concepta III Push rechts  
161986 V04 1/3

Rev.Nr.: 21.12.2023 BBU  
Rev.Nr.: 10.06.2024 BBU



DE Aussenseite K  
FR Face extérieure K  
EN Outer face K  
IT Lato esterno K  
ES Lateral exterior K

DE Beschlagseite H  
FR Côte de la ferrure H  
EN Fitting side H  
IT Lato ferramenta H  
ES Lado del herraje H

DE Türe Concepta III 25 Pull  
FR Porte Concepta III 25 Pull  
EN Door Concepta III 25 Pull  
IT Anta Concepta III 25 Pull  
ES Puerta Concepta III 25 Pull

DE Türe Concepta III 35 Push  
FR Porte Concepta III 35 Push  
EN Door Concepta III 35 Push  
IT Anta Concepta III 35 Push  
ES Puerta Concepta III 35 Push

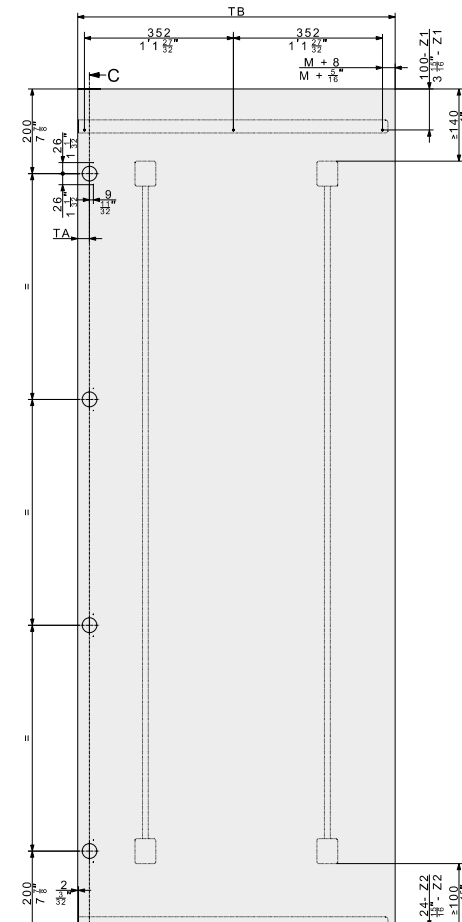
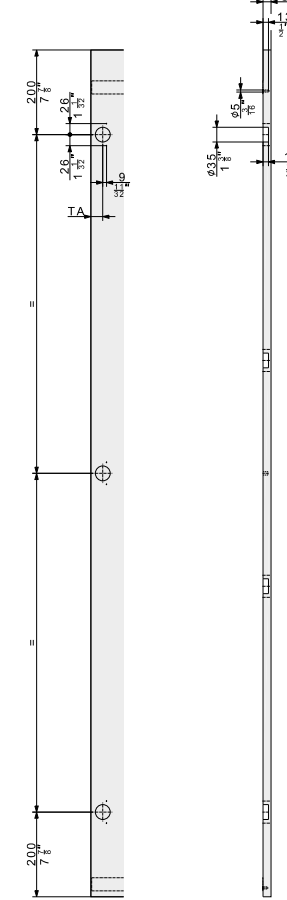
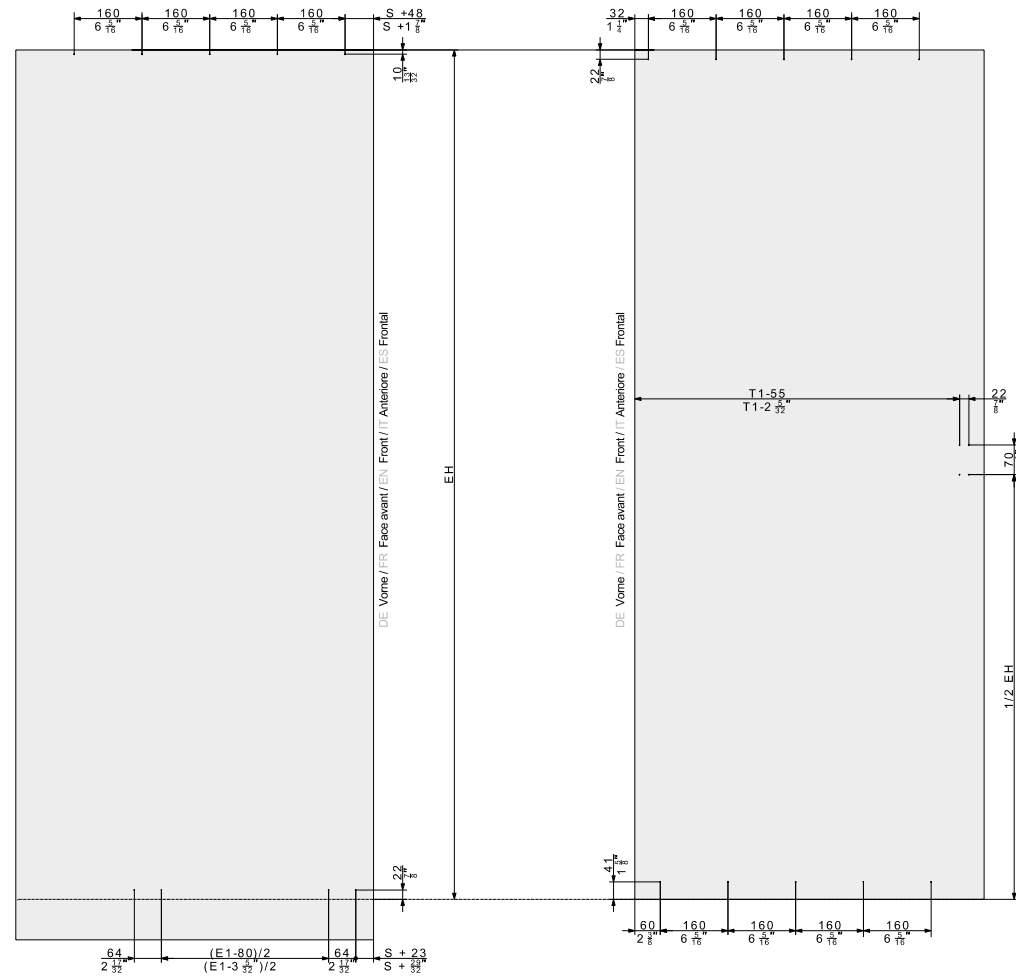

Hawa Concepta III 25 Push

DE Maximale Gewichte in kg / FR Poids maximale en kg / EN Maximum weights in kg / IT Pesi massimi in kg / ES Pesos máximos en kg

DE Türbreite / FR Largeur de porte / EN Door width / IT Larghezza anta / ES Ancho de puerta

	440	500	550	600	650	700	750
2200	25	25	25	25	25	25	24
2150	25	25	25	25	25	25	23
2100	25	25	25	25	25	24	23
2050	25	25	25	25	25	24	22
2000	25	25	25	25	25	23	21
1950	25	25	25	25	24	22	21
1900	25	25	25	25	23	21	20
1850	25	25	25	24	22	21	19
1800	25	25	25	23	21	20	19
1750	25	25	25	22	21	19	18
1700	25	25	24	22	20	19	17
1650	25	25	23	21	19	18	17
1600	25	24	22	20	18	17	16
1550	25	23	21	19	18	16	15
1500	24	22	20	18	17	16	15
1450	23	21	19	17	16	15	14
1400	22	20	18	17	15	14	13
1350	21	19	17	16	15	14	13
1300	20	18	16	15	14	13	12
1250	19	17	15	14	13	12	11
1200	18	16	15	13	12	11	11

DE Türgewicht in kg / FR Poids de porte en kg / EN Door weight in kg / IT Peso anta in kg / ES Peso de puerta en kg

Hawa Concepta III 25 Push

DE Maximale Gewichte in lbs. / FR Poids maximale en lbs. / EN Maximum weights in lbs. / IT Pesi massimi in lbs. / ES Pesos máximos en lbs.

DE Türbreite / FR Largeur de porte / EN Door width / IT Larghezza anta / ES Ancho de puerta

	1'5 5/16"	1'7 11/16"	1'9 21/32"	1'11 3/8"	2'1 13/32"	2'3 9/16"	2'5 17/32"
7'2 5/8"	55	55	55	55	55	55	53
7'0 1/2"	55	55	55	55	55	55	51
6'10 1/4"	55	55	55	55	55	55	51
6'8 3/8"	55	55	55	55	55	53	49
6'6 1/2"	55	55	55	55	55	51	46
6'4 3/4"	55	55	55	55	53	49	46
6'2 13/16"	55	55	55	55	51	46	44
6'0 1/2"	55	55	55	53	49	46	42
5'10 1/4"	55	55	55	51	46	44	42
5'8 3/8"	55	55	55	49	46	42	40
5'6 1/2"	55	55	53	49	44	42	37
5'4 3/4"	55	55	51	46	42	40	37
5'3"	55	53	49	44	40	37	35
5'1 1/8"	55	51	46	42	40	35	33
4'11 1/4"	53	49	44	40	37	35	33
4'9 3/8"	51	46	42	37	35	33	31
4'7 1/8"	49	44	40	37	33	31	29
4'5 3/4"	46	42	37	35	33	31	29
4'3 3/8"	44	40	35	33	31	29	26
4'1 1/4"	42	37	33	31	29	26	24
3'11 1/4"	40	35	33	29	26	24	24

DE Türgewicht in lbs. / FR Poids de porte en lbs. / EN Door weight in lbs. / IT Peso anta in lbs. / ES Peso de puerta en lbs.

Hawa Concepta III 35 Push

DE Maximale Gewichte in kg / FR Poids maximale en kg / EN Maximum weights in kg / IT Pesi massimi in kg / ES Pesos máximos en kg

DE Türbreite / FR Largeur de porte / EN Door width / IT Larghezza anta / ES Ancho de puerta

	440	500	550	600	650	700	750
2700	35	35	35	35	35	35	35
2650	35	35	35	35	35	35	35
2600	35	35	35	35	35	35	35
2550	35	35	35	35	35	35	35
2500	35	35	35	35	35	35	35
2450	35	35	35	35	35	35	34
2400	35	35	35	35	35	35	33
2350	35	35	35	35	35	34	32
2300	35	35	35	35	35	34	31
2250	35	35	35	35	35	33	31
2200	35	35	35	35	34	32	30
2150	35	35	35	35	33	31	29
2100	35	35	35	35	32	30	28
2050	35	35	35	34	31	29	27
2000	35	35	35	33	30	28	26
1950	35	35	35	32	29	27	26
1900	35	35	34	31	29	27	25

DE Türgewicht in kg / FR Poids de porte en kg / EN Door weight in kg / IT Peso anta in kg / ES Peso de puerta en kg

Hawa Concepta III 35 Push

DE Maximale Gewichte in lbs. / FR Poids maximale en lbs. / EN Maximum weights in lbs. / IT Pesi massimi in lbs. / ES Pesos máximos en lbs.

DE Türbreite / FR Largeur de porte / EN Door width / IT Larghezza anta / ES Ancho de puerta

	1'5 5/16"	1'7 11/16"	1'9 21/32"	1'11 3/8"	2'1 13/32"	2'3 9/16"	2'5 17/32"
8'10 5/8"	77	77	77	77	77	77	77
8'8 1/4"	77	77	77	77	77	77	77
8'6 3/8"	77	77	77	77	77	77	77
8'4 1/2"	77	77	77	77	77	77	77
8'2 1/4"	77	77	77	77	77	77	77
8'0 1/8"	77	77	77	77	77	77	75
7'10 1/4"	77	77	77	77	77	77	73
7'8 1/2"	77	77	77	77	77	75	71
7'6 3/8"	77	77	77	77	77	75	68
7'4 1/4"	77	77	77	77	77	73	68
7'2 1/8"	77	77	77	77	77	71	66
7'0 1/4"	77	77	77	77	75	73	64
6'10 1/8"	77	77	77	77	71	66	62
6'8 3/4"	77	77	77	75	68	64	60
6'6 1/2"	77	77	77	73	66	62	57
6'4 1/4"	77	77	77	71	64	60	57
6'2 1/8"	77	77	75	68	64	60	55

DE Türgewicht in lbs. / FR Poids de porte en lbs. / EN Door weight in lbs. / IT Peso anta in lbs. / ES Peso de puerta en lbs.

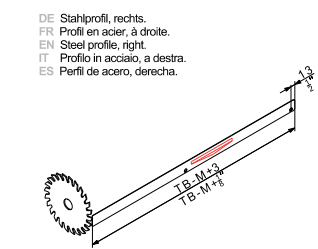
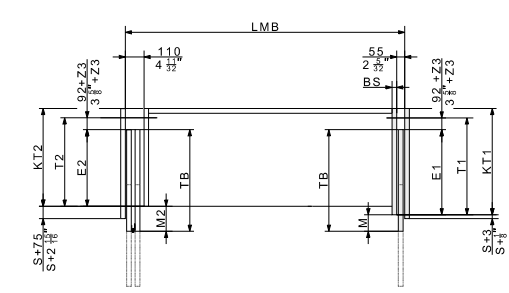
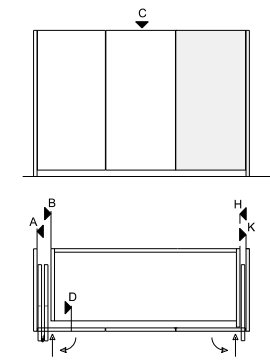

DE Stahlprofil, rechts.  
FR Profil en acier, à droite.  
EN Steel profile, right.  
IT Profilo in acciaio, a destra.  
ES Perfil de acero, derecha.

DE Abkürzungen / FR Abréviations / EN Abbreviations / IT Abbreviazioni / ES Abreviaturas

DE	FR	EN	IT	ES
BS Beschlagselendicke	Épaisseur du côté extérieur	Fitting side thickness	Spessore lato ferramenta	Grosor del lado del herraje
E Einschubtiefe	Profondeur d'encastrement	Slide-in depth	Profondità di inserimento	Profundidad de introducción
EH Einbauhöhe	Hauteur d'encastrement	Installation height	Altezza d'incasso	Altura de montaje
KT Korpusstärke	Profondeur de corps	Cabinet depth	Profondità mobile	Profundidad del mueble
LMB Lichtmassbreite	Largeur intérieure	Inside clearance	Larghezza luce	Ancho interior
M Türüberstand über Korpus	Saillie de la porte par rapport au corps	Door projection over cabinet	Sporgenza anta sopra il mobile	Solape de la puerta sobre el cuerpo
S Türdicke	Épaisseur de porte	Door thickness	Spessore anta	Grosor de la puerta
T Beschlagtiefe	Profondeur de ferrure	Hardware depth	Profondità ferramenta	Profundidad del herraje
TA Topfachsabstand	Écartement d'axe de la charnière invisible	Axis-centre distance of concealed hinge	Distanza scatola asse	Distanza de la cazoleta
TB Türbreite	Largeur de porte	Door width	Larghezza anta	Ancho de puerta
TH Türhöhe	Hauteur de porte	Door height	Altezza anta	Altura de puerta
Z Luftzwischenraum	Au dans l'espace	Air gap	Traffero d'aria	Espacio libre

DE Hawa Folding Concepta III Push links, Hawa Concepta III Push rechts  
FR Hawa Folding Concepta III Push, à gauche, Hawa Concepta III Push, à droite  
EN Hawa Folding Concepta III Push, left, Hawa Concepta III Push, right  
IT Hawa Folding Concepta III Push, a sinistra, Hawa Concepta III Push, a destra  
ES Hawa Folding Concepta III Push izquierda, Hawa Concepta III Push derecha

Hawa Folding Concepta III Push links, Hawa Concepta III Push rechts  
161986 V04 3/3