

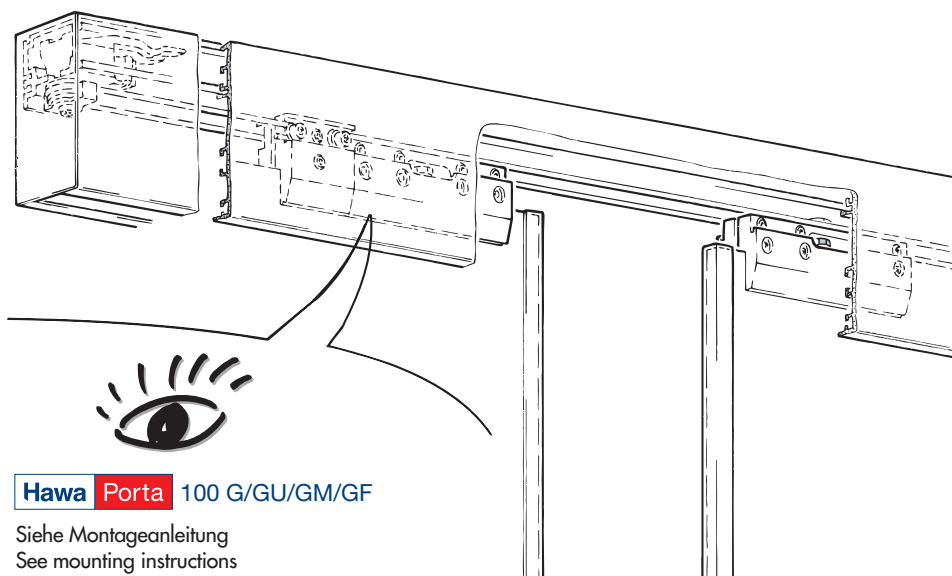





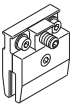

Montageanleitung Mounting instructions Instructions de montage

Hawa Porta 100 G/GF/GFO Synchro

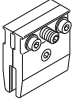

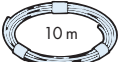
Hawa Porta 100 G/GU/GM/GF

Siehe Montageanleitung
See mounting instructions
Voir Instructions de montage
Nr. 788.2000.089

Synchro	No. 057.3075.071	
	1x	 2x
	1x	 2x
	1x	 2x
	2x	 2x

Glaskantenschutzprofil, Kunststoff, glasklar	10 mm/3000 mm	751.0001.300
Protective transparent edge trims, plastic transparent	12 mm/3000 mm	751.0002.300
Profils protecteurs de chant de verre, plastique transparent	12.7 mm/3000 mm	751.0003.300

Doppelseitiges Klebeband zu Glaskantenschutzprofil, in Rollen	50 m	751.0004.000
Double-sided adhesive tape for protective edge trims, in coils		
Ruban adhésif doubleface pour profil protecteur de chant de verre		

Glaskantenschutzprofil, Kunststoff schwarz, selbstklebend, in Rollen	10 m	057.3080.002
Protectiv edge trims, plastic black, self-adhesive, in coils		
Profils protecteurs de chant de verre, plastique noir, autocollants		

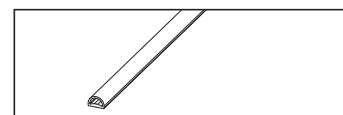
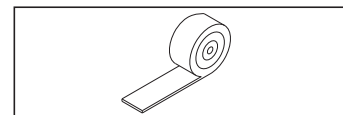
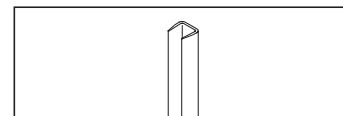

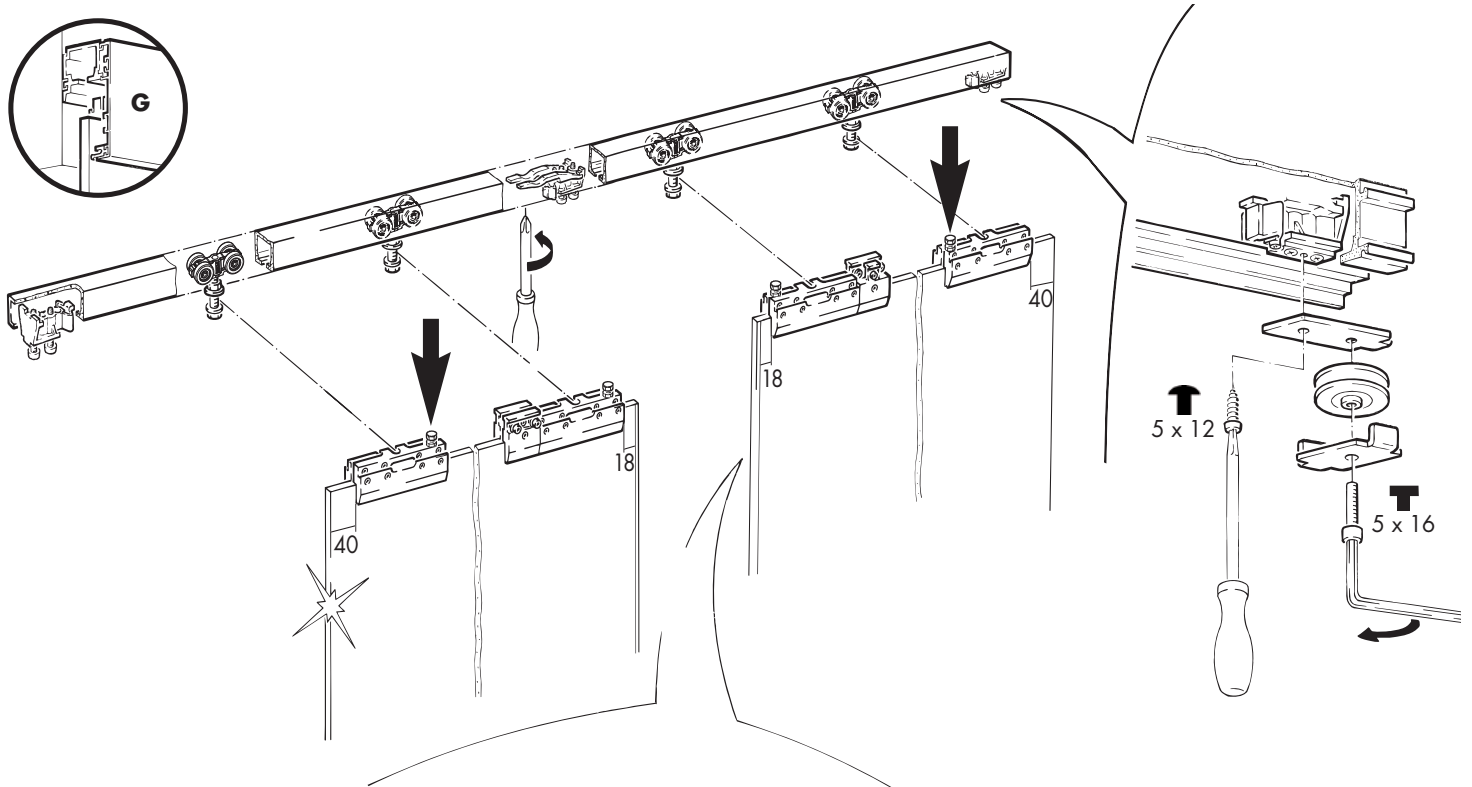

Optional/Optional/optionnell

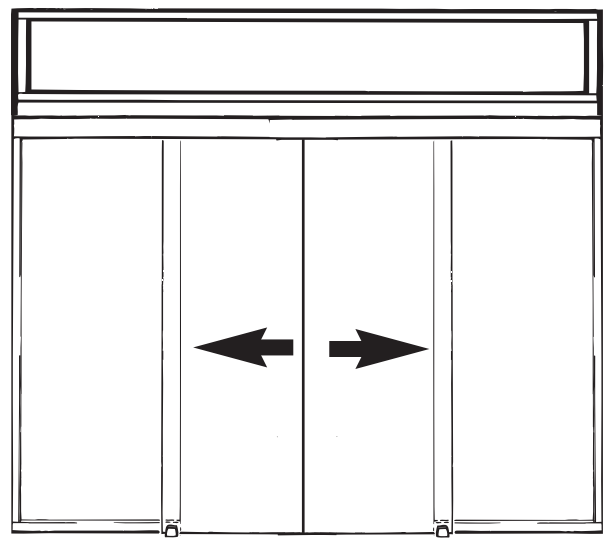
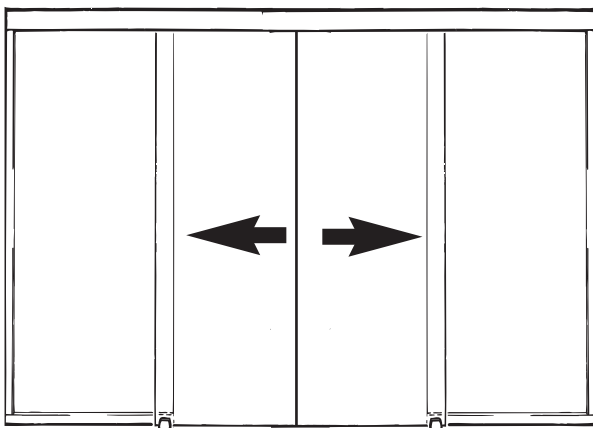
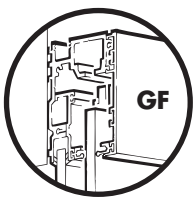
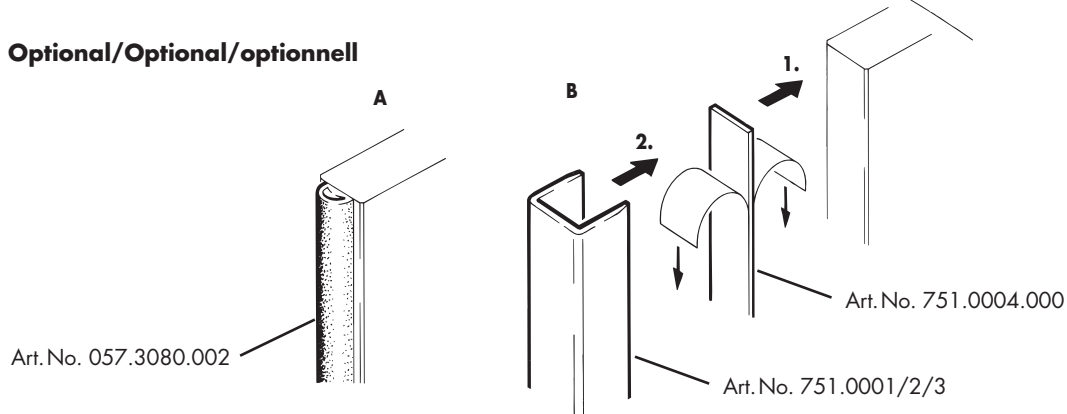

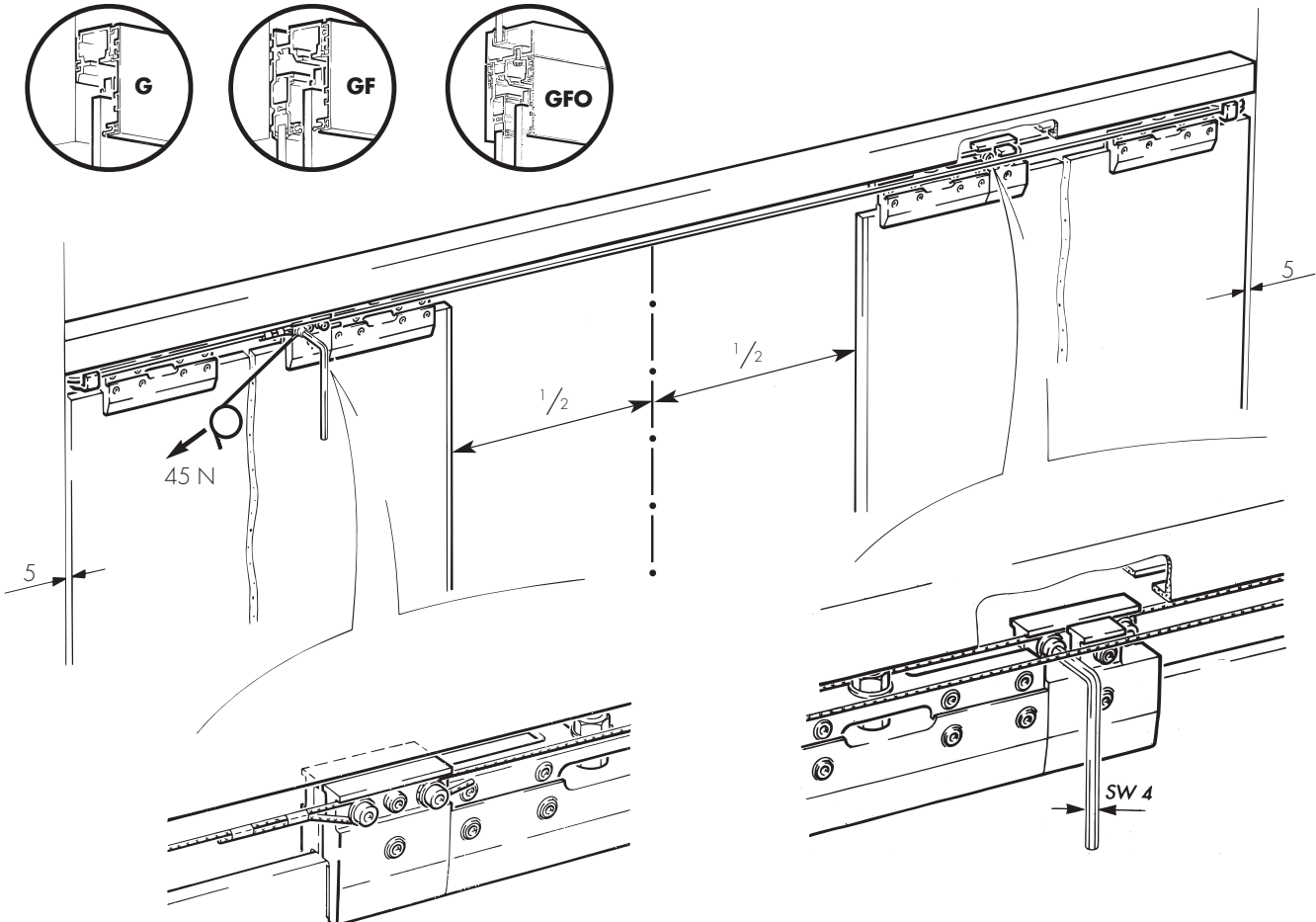
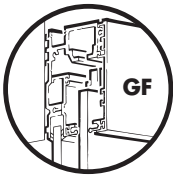
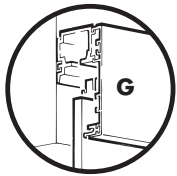
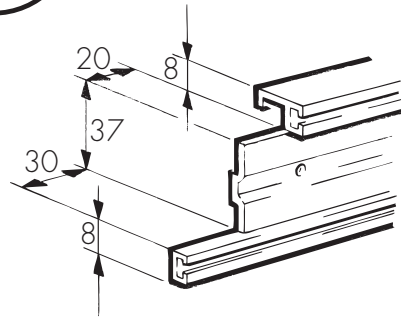
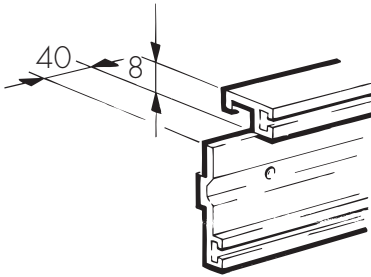
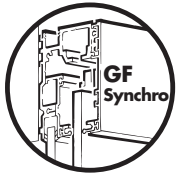
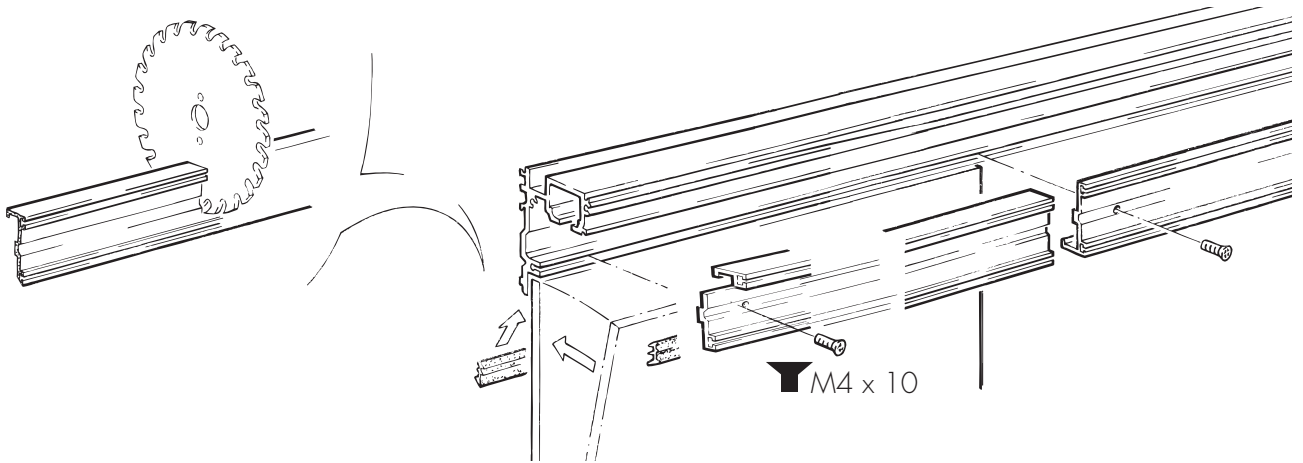

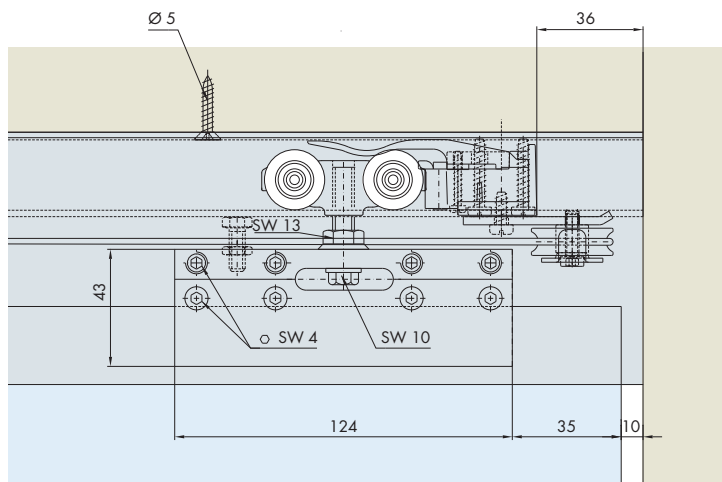
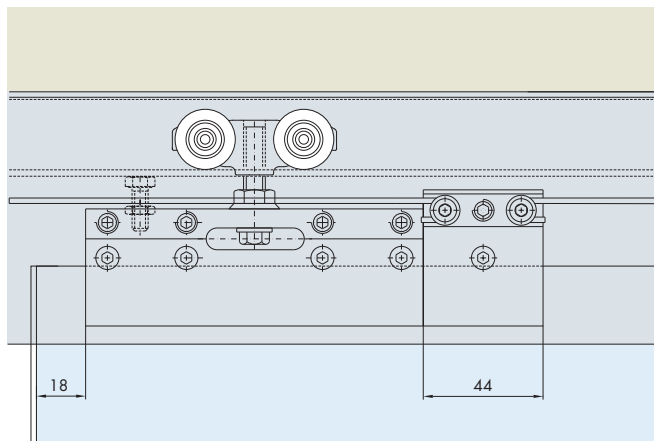

Schienenlänge/track length/Longueur du rail $S = (2 \times RO) + 80$
 Rahmenöffnung/frame opening/Ouverture du cadre = RO

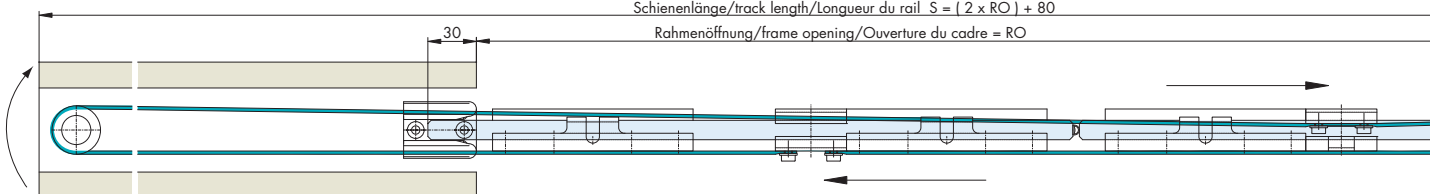

mod. G

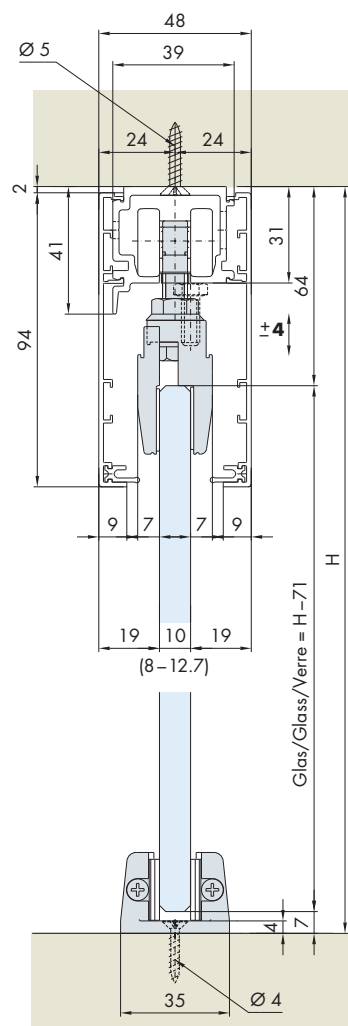

mod. GF

