



**Ferrure pour 2-3 portes en bois à roulement en bas (19/25 mm) jusqu'à 50 kg, avec rail de roulement vissé en applique. Design Mixslide sans amortissement.**

**Produits phares**

-  **Esthétique** Le système à roulement en bas avec support du poids total de la porte permet une conception d'armoire avec une faible épaisseur de matériau
-  **Confort** Coulisement léger et silencieux avec Hawa Galet de Confort

**Spécifications techniques**

-  Max. 50 kg
-  Max. 2400 mm
-  Max. 1400 mm
-  19/25 mm

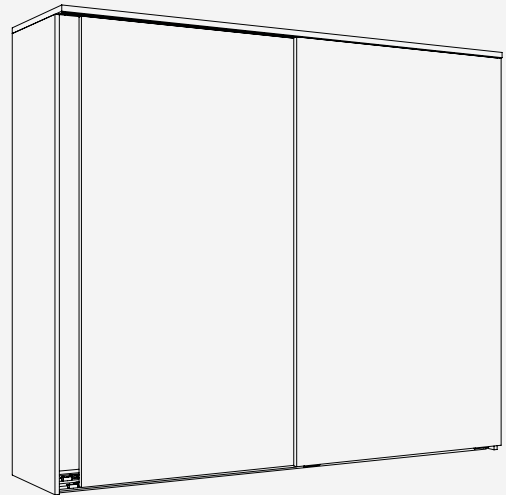



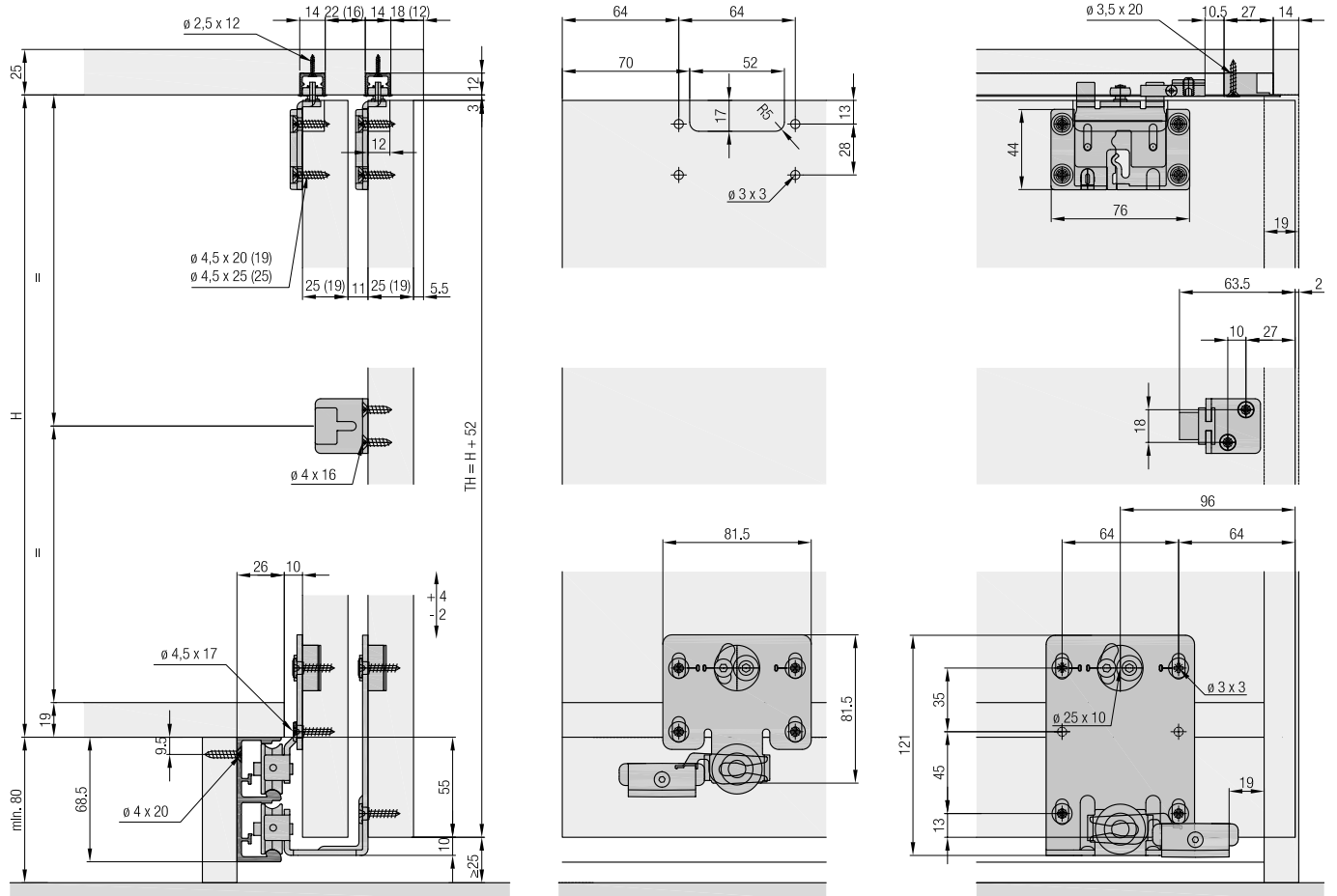













**Exemples de montage**



















**Garniture pour 2 ou 3 portes en bois, 19 mm**

	N°.
Hawa Combino 50 H MS, épaisseur de porte 19 mm, pour 2 portes	055.3199.071
Hawa Combino 50 H MS, épaisseur de porte 19 mm, pour 3 portes	055.3199.073

Garniture composée de :		055.3199.071	055.3199.073	N°.
	Chariot, porte intérieure, acier, zingué	2	4	055.3169.071
	Chariot, porte extérieure, 19 mm, acier, zingué	2	2	055.3113.175
	Équerre de guidage, acier, zingué	4	6	055.3059.171
	Boîtier équerre de guidage, plastique, anthracite	4	6	055.0282.001
	Dispositif anti-décrochage, plastique, rouge	4	6	055.0186.001
	Butée, plastique, gris	4	4	055.3167.071
	Ressort de blocage pour butée, plastique, gris	2	3	055.0204.001
	Butée guidage, plastique, gris	4	4	040.3079.074
	Entraîneur de porte, avec 2 portes, acier, zingué	1		055.3124.071
	Pièce d'extrémité du rail, plastique, gris, 31 mm	3	4	040.3083.002
	Pièce d'extrémité du rail, plastique, gris, 22 mm	1		040.3083.003
	Vis combi, 4,5x17 mm, acier, zingué	16	24	055.0100.101
	Vis à tête fraisée, 4,5x20 mm, acier, zingué	16	24	600.0000.167
	Vis à tête fraisée, 3,5x20 mm, acier, zingué	4	4	766.5035.120
	Entraîneur de porte, pour 3 portes, kit de 2 pièces, acier, zingué		1	056.3095.171
	Butée, avec adhésif, kit de 2 pièces		1	053.3364.051

**Garniture pour 2 ou 3 portes en bois, 25 mm**

	N°.
Hawa Combino 50 H MS, épaisseur de porte 25 mm, pour 2 portes	055.3199.072
Hawa Combino 50 H MS, épaisseur de porte 25 mm, pour 3 portes	055.3199.074

Garniture composée de :		055.3199.072	055.3199.074	N°.
	Chariot, porte intérieure, acier, zingué	2	4	055.3169.071
	Chariot, porte extérieure, 25 mm, acier, zingué	2	2	055.3114.175
	Équerre de guidage, acier, zingué	4	6	055.3059.171
	Boîtier équerre de guidage, plastique, anthracite	4	6	055.0282.001
	Dispositif anti-décrochage, plastique, rouge	4	6	055.0186.001
	Butée, plastique, gris	4	4	055.3167.071
	Ressort de blocage pour butée, plastique, gris	2	3	055.0204.001
	Butée guidage, plastique, gris	4	4	040.3079.074
	Entraîneur de porte, avec 2 portes, acier, zingué	1		055.3124.071
	Pièce d'extrémité du rail, plastique, gris, 31 mm	3	4	040.3083.002
	Pièce d'extrémité du rail, plastique, gris, 22 mm	1		040.3083.003
	Vis combi, 4,5x17 mm, acier, zingué	16	24	055.0100.101
	Vis à tête fraisée, 4,5x25 mm, acier, zingué	16	24	766.5045.125
	Vis à tête fraisée, 3,5x20 mm, acier, zingué	4	4	766.5035.120
	Entraîneur de porte, pour 3 portes, kit de 2 pièces, acier, zingué		1	056.3095.171
	Butée, avec adhésif, kit de 2 pièces		1	053.3364.051

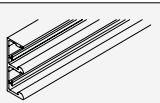

**Rails de roulement**

		mm	N°.
	Rail de roulement double, aluminium, anodisé, percé	2500	055.3161.250
		3500	055.3161.350
		6000	055.3161.600

**Rails de guidage**

		mm	N°.
	Rail de guidage, aluminium, percé	2500	056.3079.250
		3500	056.3079.350
		6000	056.3079.600

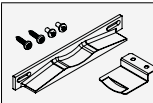
**Accessoires**

		N°.
	Kit de butées intermédiaires, pour 3 portes	055.3218.071
	Gabarit de perçage et de fraisage, pour l'usinage de l'équerre de guidage, bois	055.3099.001

**Calculs**

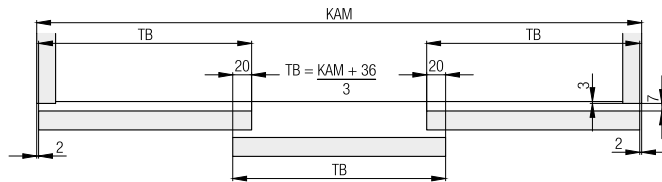
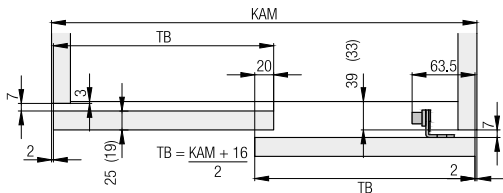

**Pièce d'extrémité du rail**

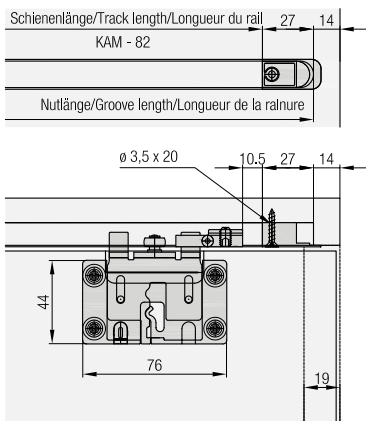

**Butée intermédiaire avec 3 portes**

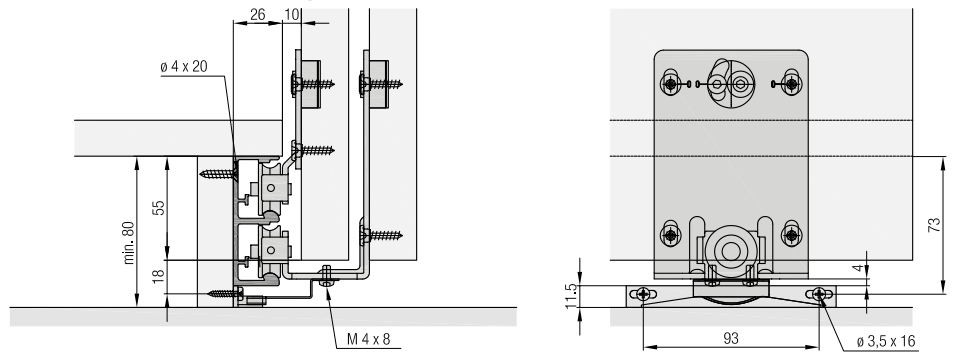

**Profils de poignée**

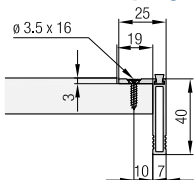

**Accessoires**

- Ferrure de redressement à partir de la page 317
- Profils de poignée à partir de la page 320

**Planification/exécution**

Plus d'informations sur le produit sont disponibles sur [www.hawa.com](http://www.hawa.com).