

Planung und Montage

Beschlag für Glasschiebewände parallel zur Schiebeachse gestapelt.

Planification et montage

Ferrures pour cloisons coulissantes en verre, avec rangement parallèle à l'axe de coulissement.

Planning and installation

Hardware system for glass sliding walls that are stacking parallel to the slide axis.

Pianificazione e montaggio

Ferramenta per porte scorrevoli in vetro parcheggiate parallelamente all'asse di scorrimento.

Planificación y montaje

Herraje para mamparas deslizantes de cristal apiladas paralelo al eje del deslizamiento.

■ Hawa Teile ■ Eléments Hawa ■ Hawa components ■ Componenti Hawa ■ Componentes Hawa

NOTICE: Metric dimensions are valid – dimensions stated in inches are for information only.

Diese Zeichnung ist Eigentum der Hawa AG und darf weder verwertet, vervielfältigt noch Dritten zugänglich gemacht werden. Alle unsere Katalog-Zeichnungen sowie die speziellen Einbauzeichnungen im Massstab 1:1 usw. stellen Beispiele zum Einbau unserer Beschläge dar. Irgendwelche Ansprüche aus der Verwendung dieser Unterlagen können durch den Kunden nicht abgeleitet werden. Für bau-/projektbezogene, konstruktive Details wird keine Verantwortung übernommen.

Ce plan est la propriété de Hawa AG. Il ne peut être utilisé à titre lucratif, ni photocopié ou transmis à un tiers. Tous les plans publiés dans les catalogues, les plans de montage spéciaux à l'échelle 1:1 etc. représentent des exemples de montage de nos ferrures. Le client ne peut tirer des droits quelconques en utilisant de tels documents. Pour des détails constructifs touchant aux projets ou aux sites, toute responsabilités est déclinée.

This drawing remains the property of Hawa AG and may not be sold, reproduced or made available to third parties. All of our catalogue drawings and special full scale installation drawings etc. represent installations using our hardware and fittings. No claims on the part of the customers can be considered which arise in connection with the use of these documents. For site or project-related design details any liability is declined.

Questo disegno è proprietà di Hawa AG e non può essere usato a scopo di lucro, riprodotto e reso accessibile a terzi. Tutti i nostri disegni del catalogo nonché i particolari disegni di montaggio in scala 1:1 ecc. rappresentano esempi per il montaggio delle nostre ferramenta. Eventuali rivendicazioni a seguito dell'utilizzo di questa documentazione non possono essere evidenziate da parte del cliente. Non assumiamo nessuna responsabilità per dettagli costruttivi che riguardano qualsiasi costruzione o progetto.

Este documento es propiedad de la empresa Hawa AG. Se excluye la venta y reproducción, al igual que el acceso a terceras personas. Los planos contenidos en nuestros catálogos, al igual que los planos especiales de montaje a escala 1:1 etc. representan ejemplos para el montaje de nuestros herrajes. Su uso no implica la deducción de derechos, cualquiera sea su naturaleza, por parte del cliente. No asumimos ninguna responsabilidad por los detalles constructivos relativos a la construcción o proyectos.

<p>-</p> <p>19200</p>	<p>b</p>	Gezeichnet/Dessiné/Drafted/Disegnato/Dibujado 04.2003 / STJ	Internationale Schutzrechte Änderungen vorbehalten Droits internationaux déposés Sous réserve de modifications Swiss and foreign patents Design subject to modification Diritti protettivi internazionali Con riserva di apportare modifiche Derechos internacionales protegidos Planos sujetos a modificaciones
		Änderung/Modification/Modification/Modifica/Modificación 08.2014 / RHU	
		Ersetzt/Remplace/Replaces/Sostituisce/Reemplaza 19200a	
		Visum/Visa/Visa/Visado 09.2014 / MFR	

06.2003 / MFR (2956)
 a) 12.2005 / BKU (3519)
 b) 15.05.2008 / MFR (4078)
 11.2011 BtT (4786)

Deutsch

Hawa Aperto 60 GL

Normstapelraum für 8 Schiebe- und 1 Drehtüre
Maximales Türgewicht 60 kg
Maximale Türhöhe 2600 mm
Minimale Türbreite 500 mm
Maximale Schiebetürbreite 1100 mm
Maximale Drehtürbreite 1200 mm
Glasdicke ESG-Glas 8/10 mm/ $\frac{3}{8}$ " USA
Es darf ausschliesslich Einscheiben-Sicherheitsglas (ESG) verwendet werden.

Spezialanlage Rücksprache mit Hawa Sliding Solutions AG

Français

Hawa Aperto 60 GL

Espace de parcage standard p. 8 portes coulissantes et 1 porte pivotante
Poids maximum par porte 60 kg
Hauteur maximum par porte 2600 mm
Largeur minimum par porte 500 mm
Largeur maximum par porte coulissante 1100 mm
Largeur maximum par porte pivotante 1200 mm
Epaisseurs de glace ESG 8/10 mm/ $\frac{3}{8}$ " USA
Il faut utiliser uniquement du verre de sécurité trempé (ESG).

Modèle spécial, veuillez consulter Hawa Sliding Solutions AG

English

Hawa Aperto 60 GL

Standard parking area for 8 sliding doors and 1 pivot door
Maximum door weight 60 kg (132 lbs.)
Maximum door height 2600 mm (8'6 $\frac{3}{8}$ ")
Minimum door width 500 mm (1'7 $\frac{11}{16}$ ")
Maximum sliding door width 1100 mm (3'7 $\frac{5}{16}$ ")
Maximum pivot door width 1200 mm (3'11 $\frac{1}{4}$ ")
Glass thicknesses ESG fully tempered monolithic glass 8/10 mm
($\frac{5}{16}$ " / $\frac{13}{32}$ ") / $\frac{3}{8}$ " USA
Merely fully tempered monolithic glass (ESG) may be employed.

Special model, please consult Hawa Sliding Solutions AG

Italiano

Hawa Aperto 60 GL

Parcaggio normalizzato per 8 porte scorrevoli e 1 porta girevole
Peso massimo della porta 60 kg
Altezza massima della porta 2600 mm
Larghezza minima della porta 500 mm
Larghezza massima della porta scorrevole 1100 mm
Larghezza massima della porta girevole 1200 mm
Spessore del vetro ESG 8/10 mm/ $\frac{3}{8}$ " USA
È permesso usare esclusivamente vetro di protezione monovetro (ESG).

Impianto speciale, consultare la Hawa Sliding Solutions AG

Español

Hawa Aperto 60 GL

Área de apilado normalizado para 8 paneles deslizantes y 1 puerta pivotante
Peso máximo del panel 60 kg
Altura máxima del panel 2600 mm
Ancho mínimo del panel 500 mm
Ancho máximo del panel deslizante 1100 mm
Ancho máximo de puerta pivotante 1200 mm
Espesor del cristal ESG 8/10 mm/ $\frac{3}{8}$ " USA
Debe ser utilizado exclusivamente cristal de seguridad monolítico, no laminado (ESG).

En caso de instalaciones especiales consultar con
Hawa Sliding Solutions AG

Inhaltsverzeichnis

Inhaltsverzeichnis	3
Vertikalschnitt	4
Anlage-Typen	5
Berechnungen	6–9
Glasausschnitt / Glasberechnung	10
Bestellung Glastüren	11
Position Komponenten	12–14
Montage	15–24
Beschlägeübersicht	25

Sommaire

Sommaire	3
Coupe verticale	4
Types d'installations	5
Calculs	6–9
Découpe de verre / calcul de verre	10
Commande des portes en verre	11
Position des composants	12–14
Montage	15–24
Composants de la ferrure	25

Contents

Contents	3
Vertical section	4
System types	5
Calculations	6–9
Glass cutout / glass calculation	10
Order for glass doors	11
Position of components	12–14
Mounting	15–24
Hardware system components	25

Indice

Indice	3
Sezione verticale	4
Tipi sistemi	5
Calcoli	6–9
Intaglio del vetro / calcolo del vetro	10
Ordinazione porte di vetro	11
Posizioni dei componenti	12–14
Montaggio	15–24
Assortimento ferramenta	25

Contenido

Contenido	3
Sección vertical	4
Tipos de sistemas	5
Cálculos	6–9
Muecas en el cristal / cálculo del cristal	10
Pedido de paneles de cristal	11
Posición de componentes	12–14
Montaje	15–24
Componentes de los herrajes	25

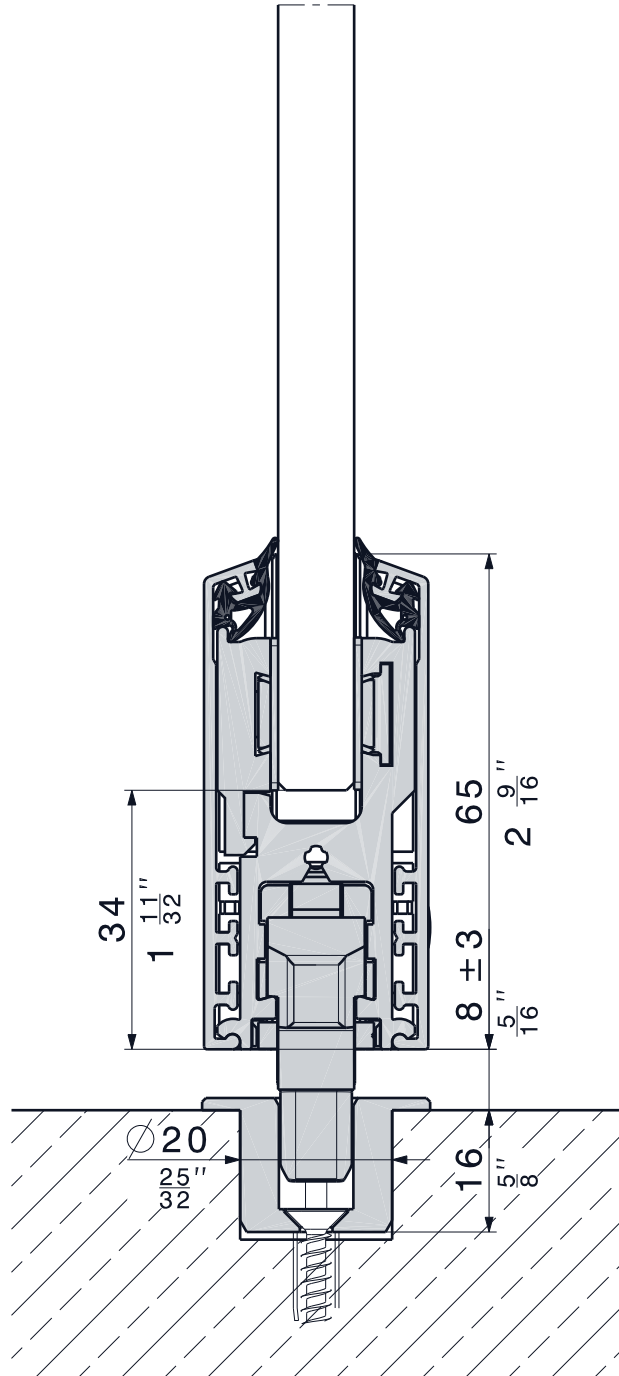
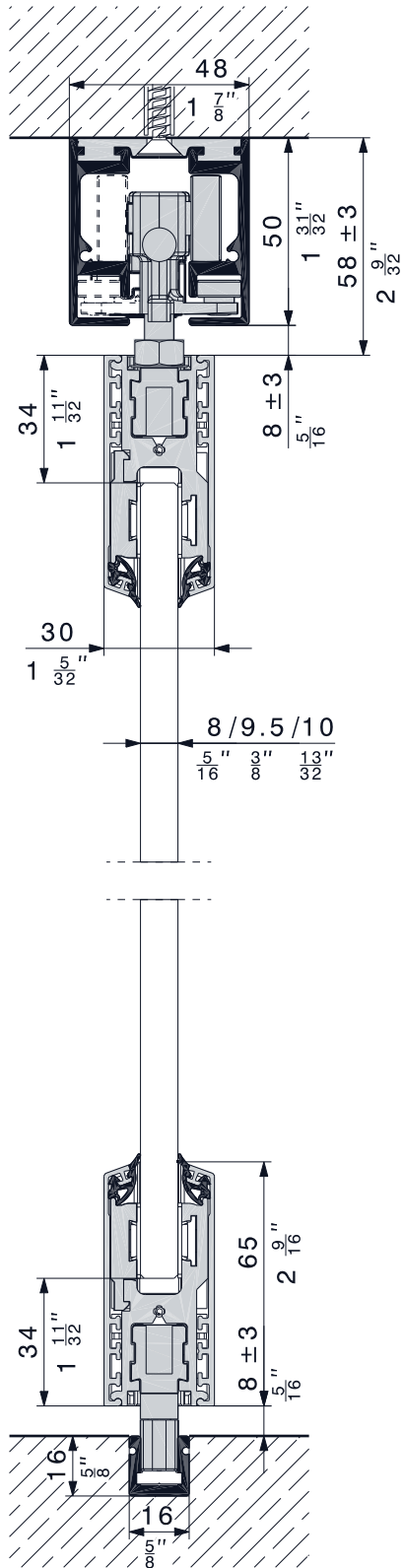

Technische Änderungen vorbehalten
 Sous réserve de modifications techniques
 Subject to modification

Con riserva di apportare modifiche tecniche
 Bajo reserva de modificaciones técnicas

Anlage-Typen
Types d'installations
System types
Tipi sistemi
Tipos de sistemas

Mit Führungsschiene
 Avec rail de guidage
 With bottom guide channel
 Con guida
 Con riel de guía

Ohne Führungsschiene
 Sans rail de guidage
 Without bottom guide channel
 Senza guida
 Sin riel de guía

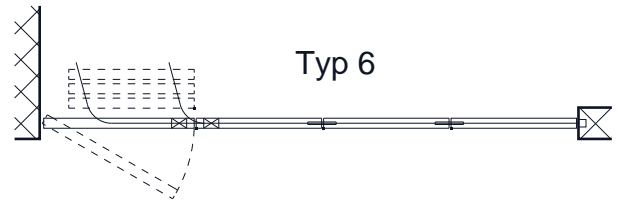
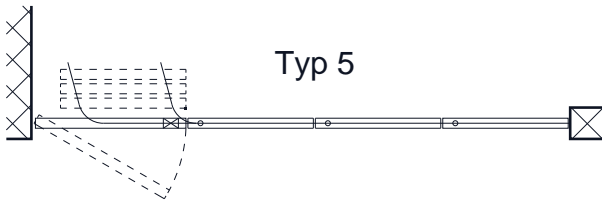
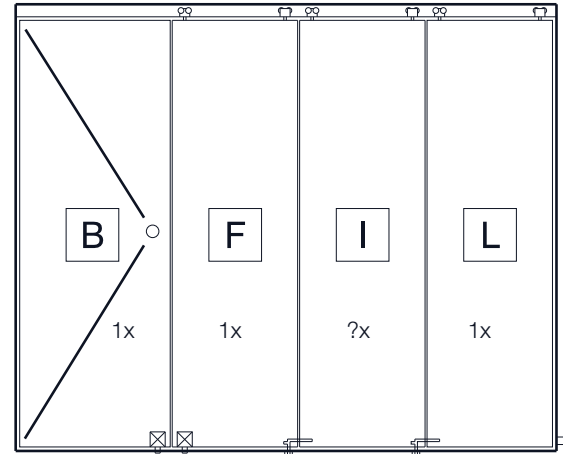
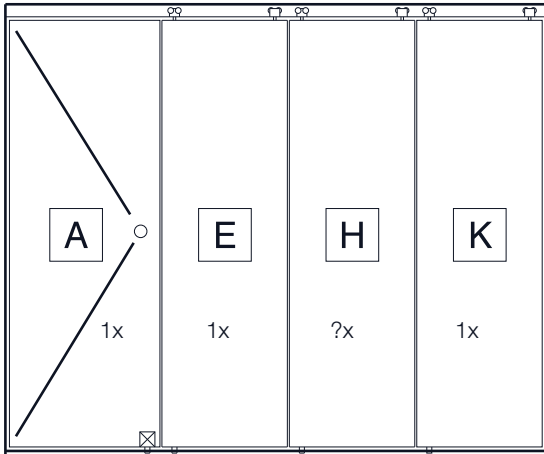

Typ 5

Typ 6

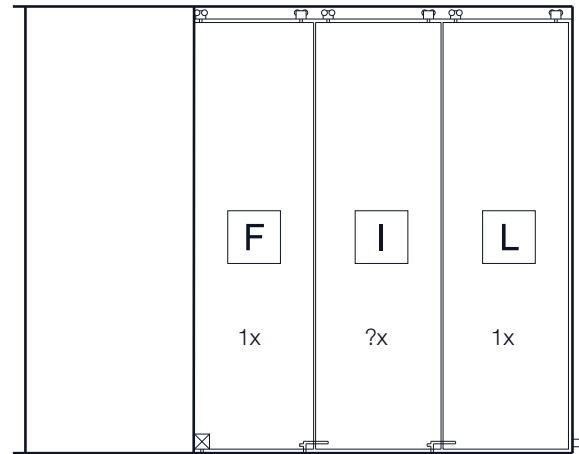
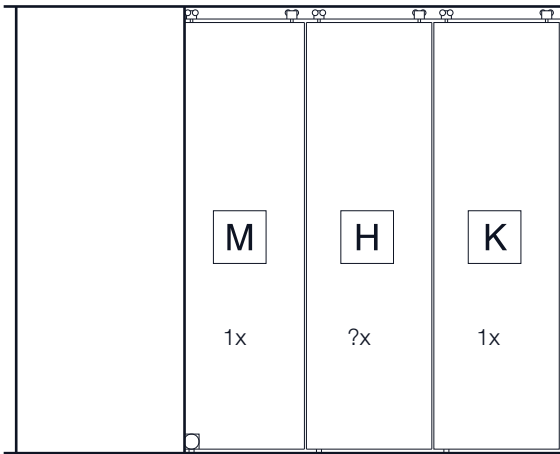

Typ 7

Typ 8

- Rundriegelschloss mit Führungszapfen
 Serrure à verrou rond avec goujon de guidage
 Round bar lock with guide pin
 Serratura a chiavistello tondo con perno di guida
 Pasador de vástago redondo con rodillo de guía

- ⊗ Rundriegelschloss
 Serrure à verrou rond
 Round bar lock
 Serratura a chiavistello tondo
 Pasador de vástago redondo

Berechnungen ab Lichtmassbreite (LMB) für Anlagen mit Drehtüre
Calculs à partir de la largeur intérieure (LMB) pour installations avec portes pivotantes
Calculations as from the inside width (LMB) for installations with pivot doors
Calcolo a partire dalla larghezza interna (LMB) per costruzioni con porte girevoli
Cálculo a partir del ancho de luz (LMB) para instalaciones con puertas pivotantes

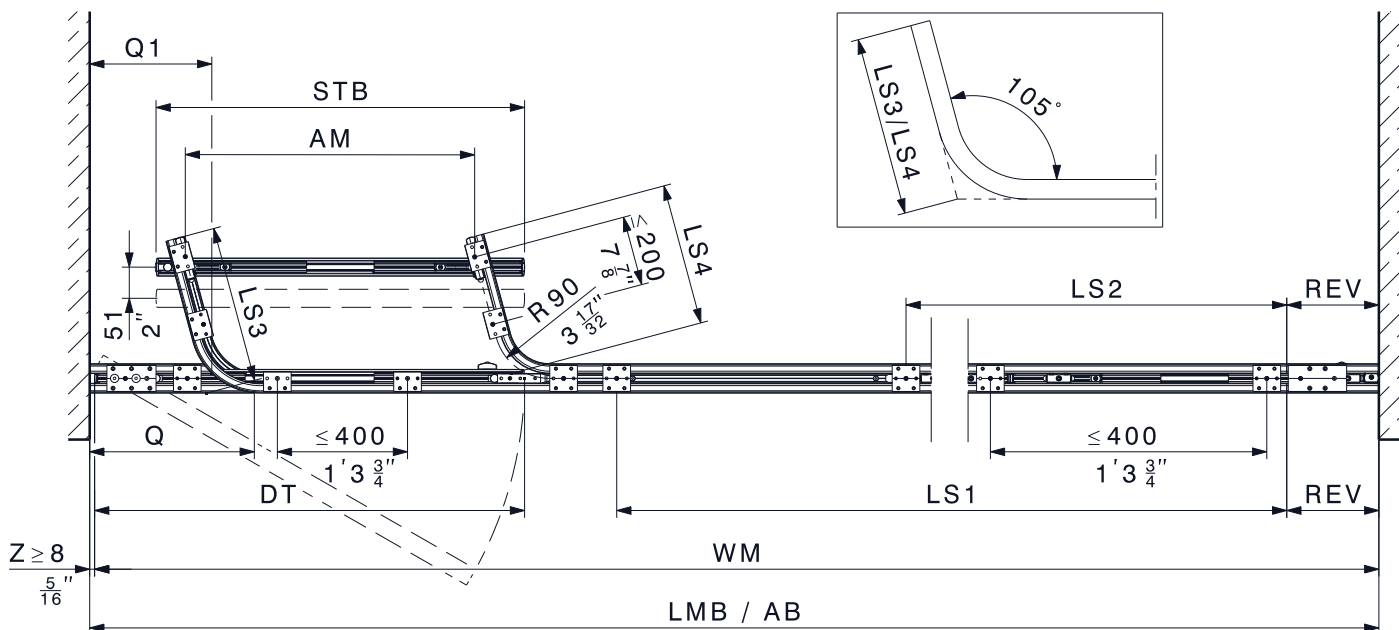

AB =	Anlagenbreite Largeur d'installation Installation width Larghezza installazione Ancho de instalación
AM =	Achsmass Cote axiale Axial dimension Dimensione asse Dimensión de eje
AT =	Anzahl Türen inkl. Drehtüre Nombre de portes, y compris porte pivotante Number of doors, including pivot door Numero porte, incl. porta girevole Número de paneles, incluido puerta pivotante
DT =	Drehtüre Porte pivotante Pivot door Porta girevole Puerta pivotante
LMB =	Lichtmassbreite Largeur intérieur Inside width Larghezza interna Ancho de luz
LS =	Laufschiene Rail de roulement Top track Binario Riel de rodadura
REV =	Laufschiene-Endstück Embout pour rails de roulement End-piece for top tracks Finecorsa binario Pieza final del riel de rodadura

Z =	
REV =	150
AT =	
LMB =	

$WM = LMB - Z$	
$STB = \frac{WM - 100}{AT}$	
$DT = STB + 100$	
$AM = STB - 73 - (AT \times 14)$	
$Q = 212 + (AT \times 14)$	
$LS1 = LMB - Q - 590 - REV$	
$LS2 = LS1 - AM$	
$LS3 = 53 + (AT \times 51)$	
$LS4 = LS3 - 25$	
$Q1 = Q - 68$	

Technische Änderungen vorbehalten
 Sous réserve de modifications techniques
 Subject to modification

Con riserva di apportare modifiche tecniche
 Bajo reserva de modificaciones técnicas

Berechnungen ab Mass P für Anlagen mit Schiebetüren
Calculs à partir de la cote P pour installations avec portes coulissantes
Calculations based on dimension P for installations with sliding doors
Calcoli a partire dalla misura P per costruzioni con porte scorrevoli
Cálculos a partir de la dimensión P para instalaciones con paneles deslizantes

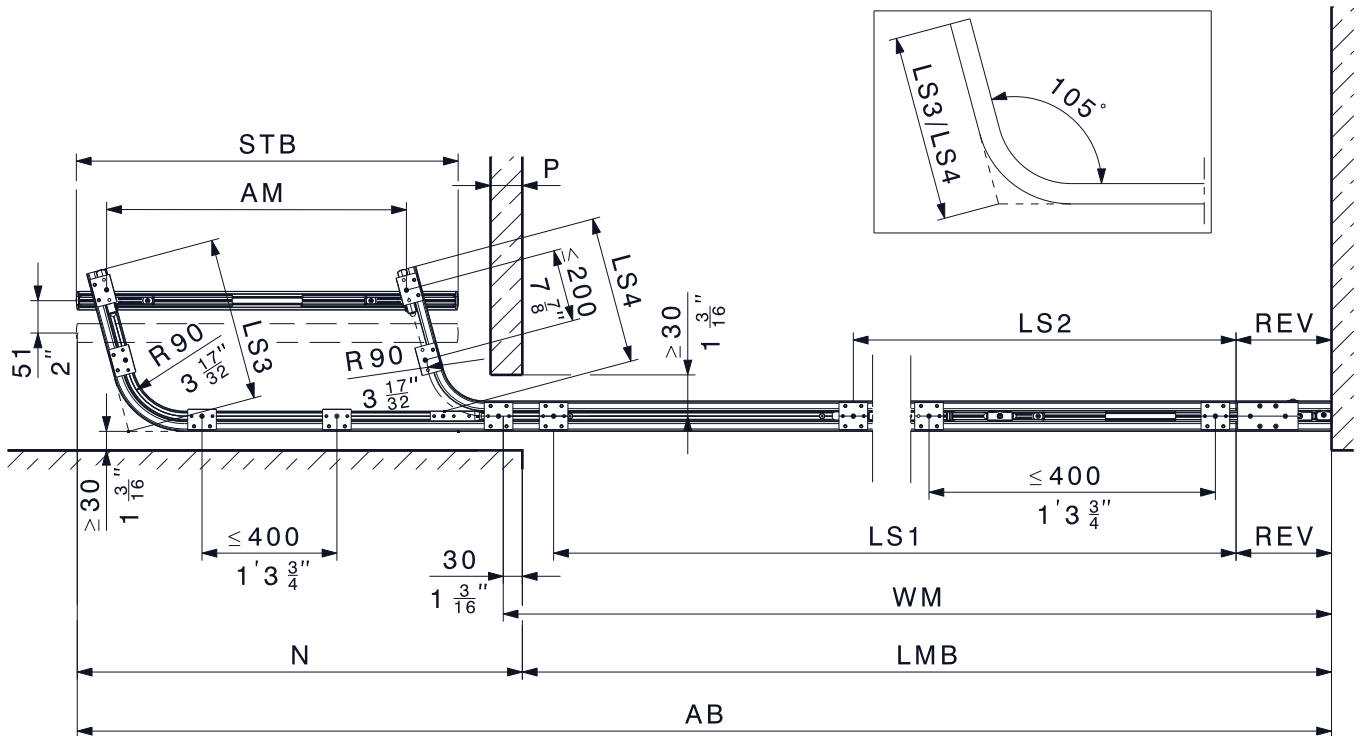

ST =	Anzahl Schiebetüren Nombre de portes coulissantes Number of sliding panels Numero porte scorrevoli Número de paneles deslizantes
STB =	Schiebetürbreite Largeur de la porte coulissante Sliding door width Larghezza porta scorrevole Ancho del panel deslizante
WM =	Glasschiebewandmass Cote de la cloison coulissante Dimension of glass sliding wall Dimensione della parete scorrevole di vetro Ancho toal del tabique deslizante de vidrio
Z =	Luft Wand bis Türe Jeu entre mur et porte Clearance between wall and door Aria entre parete e porta Luz entre el muro y panel

	P
REV =	150
ST =	
LMB =	
P =	

	P
WM =	LMB + 30
STB =	$\frac{WM}{ST}$
AM =	STB - 86 - (ST x 14)
LS1 =	LS2 + AM
LS2 =	P + LMB - REV - 552 + (ST x 14)
LS3 =	(ST x 51) + 104
LS4 =	LS3 - 25
AB =	LMB + P + 64 + STB + (ST x 14)

Technische Änderungen vorbehalten
 Sous réserve de modifications techniques
 Subject to modification

Con riserva di apportare modifiche tecniche
 Bajo reserva de modificaciones técnicas

Berechnungen ab Mass N für Anlagen mit Schiebetüren
Calculs à partir de la cote N pour installations avec portes coulissantes
Calculations based on dimension N for installations with sliding doors
Calcoli a partire dalla misura N per costruzioni con porte scorrevoli
Cálculos a partir de la dimensión N para instalaciones con paneles deslizantes

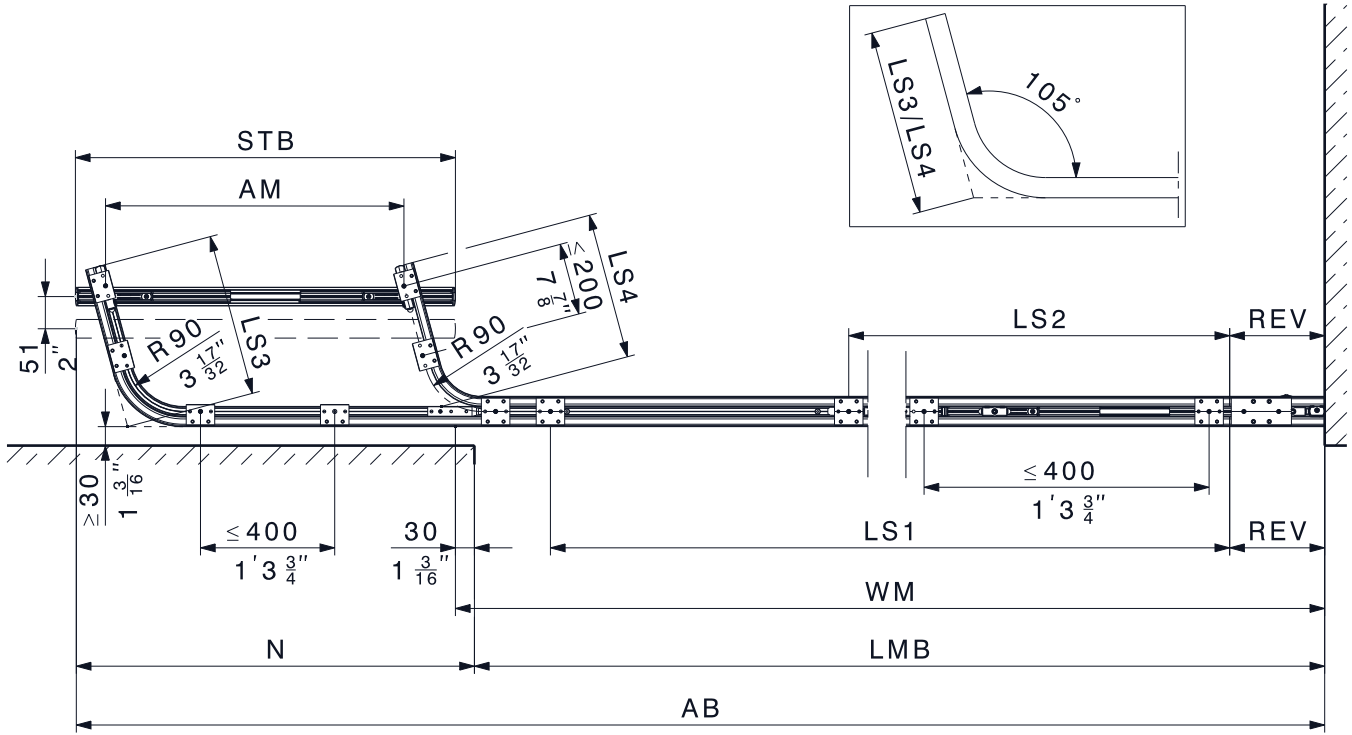

	N
REV =	150
ST =	
LMB =	

	N
WM =	$LMB + 30$
STB =	$\frac{WM}{ST}$
AM =	$STB - 86 - (ST \times 14)$
N =	STB
LS1 =	LS2 + AM
LS2 =	$LMB - REV - 36 - 580$
LS3 =	$(ST \times 51) + 104$
LS4 =	LS3 - 25
AB =	LMB + N

Technische Änderungen vorbehalten
 Sous réserve de modifications techniques
 Subject to modification

Con riserva di apportare modifiche tecniche
 Bajo reserva de modificaciones técnicas

Berechnung Stapelraum-Innenverblendung, Führungsschiene
Calcul de cache intérieur pour espace de parcage, rail de guidage
Calculation of the stacking area inside covers, bottom guide channel
Calcolo zona di stipa-rivestimento interno, guida
Cálculo del área de apilado con perfil de cobertura a la vista, riel de guía

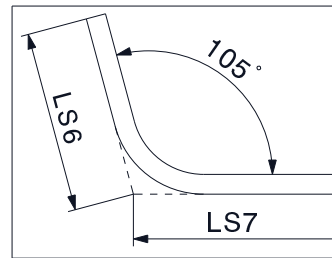
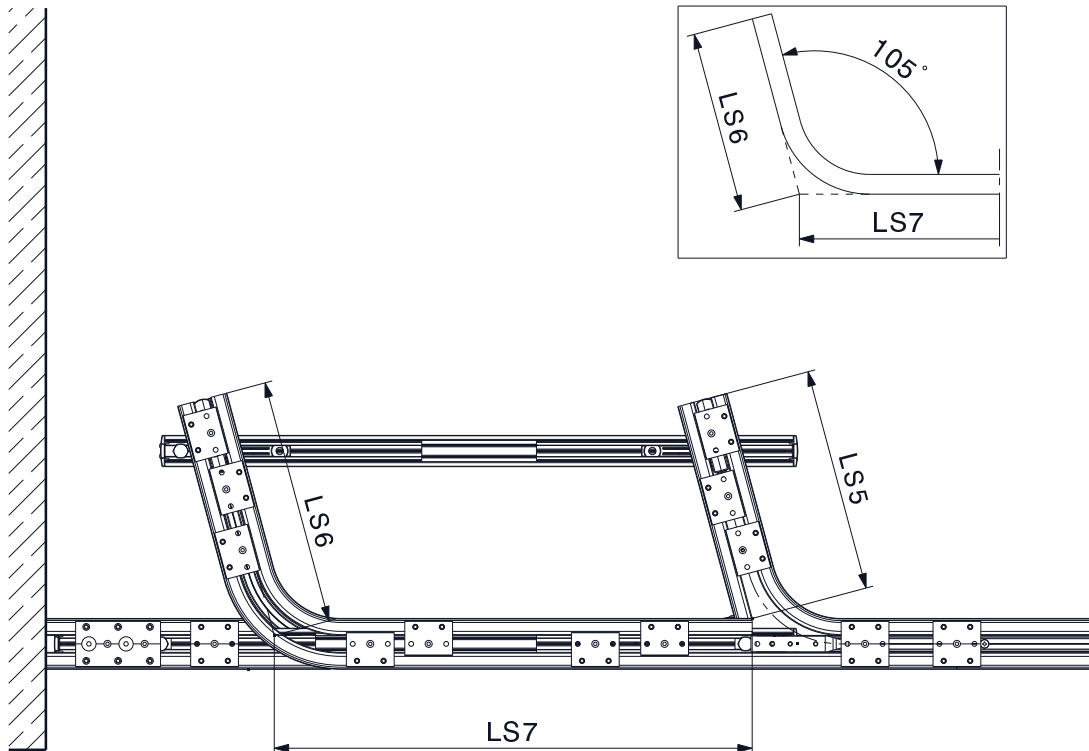

AM =	
LS1 =	
LS3 =	
LS4 =	

siehe Seite 6-8
 voir pages 6-8
 see pages 6-8
 vedi pagine 6-8
 ver páginas 6-8

LS5 = LS4 - 21	
LS6 = LS3 - 25	
LS7 = AM - 21	

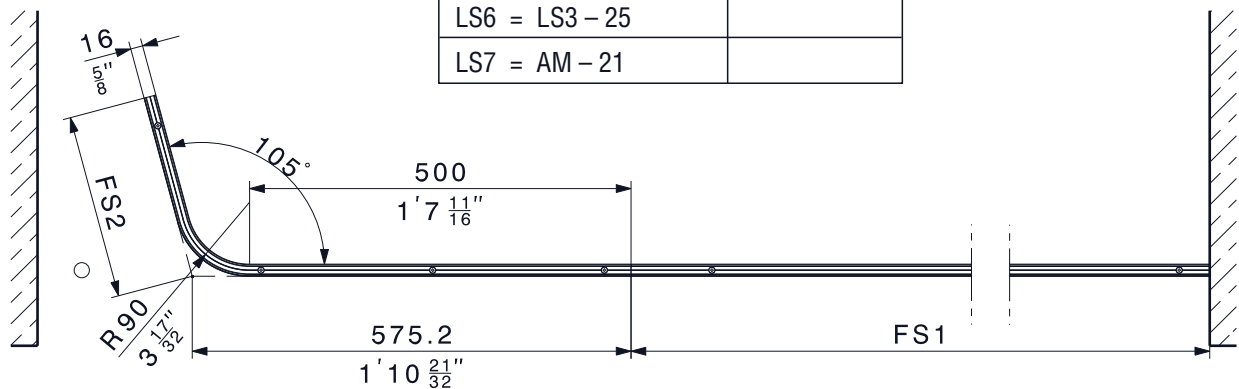

LS =	Laufschiene Rail de roulement Top track Binario Riel de rodadura
FS =	Führungsschiene Rail de guidage Bottom guide channel Guida Riel de guía

FS1 = LS1 + 230	
FS2 = LS3 - 13	

*Glasausschnitt / Glasberechnung
 Découpe de verre / calcul de verre
 Glass cutout / glass calculation
 Intaglio del vetro / calcolo del vetro
 Muecas en el cristal / cálculo del cristal*

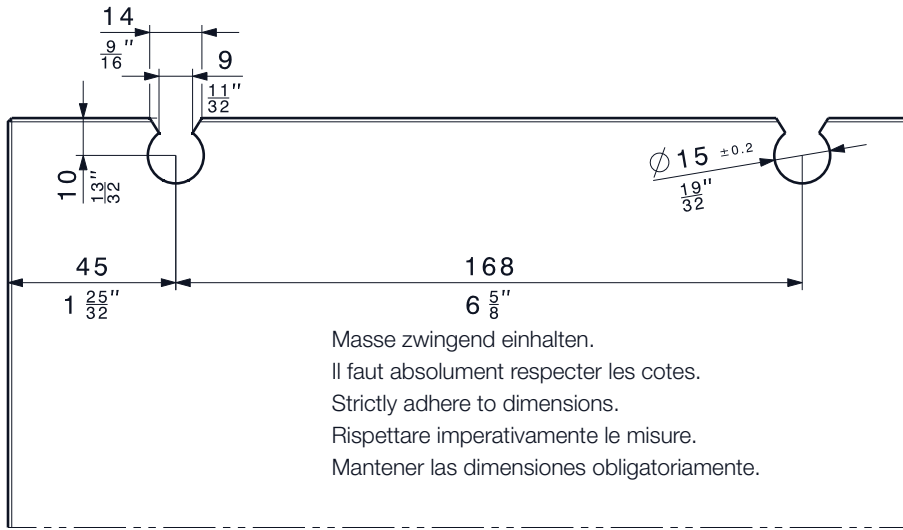

Masse zwingend einhalten.
 Il faut absolument respecter les cotes.
 Strictly adhere to dimensions.
 Rispettare imperativamente le misure.
 Mantener las dimensiones obligatoriamente.

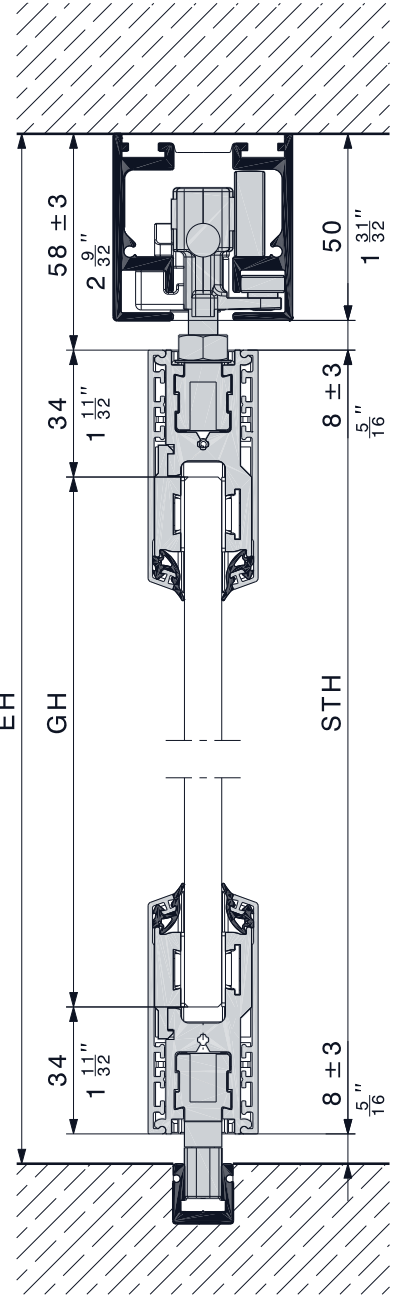
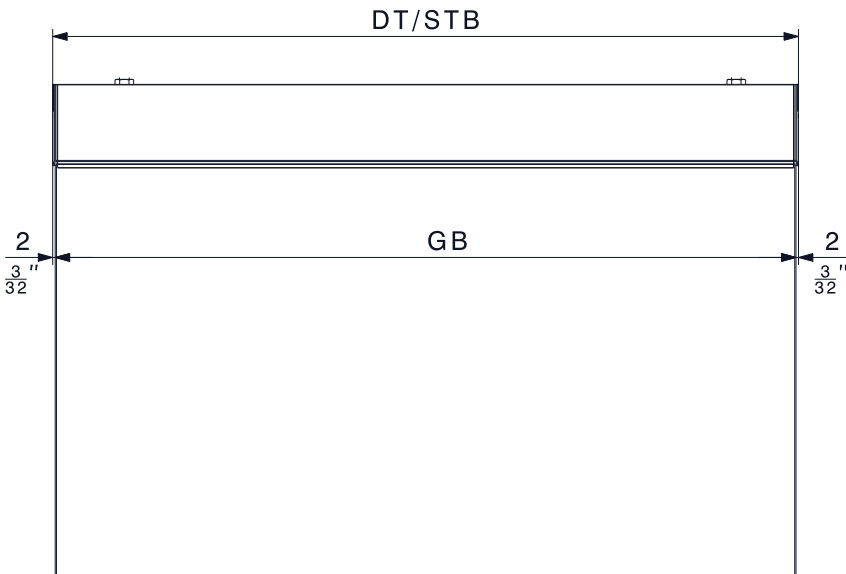
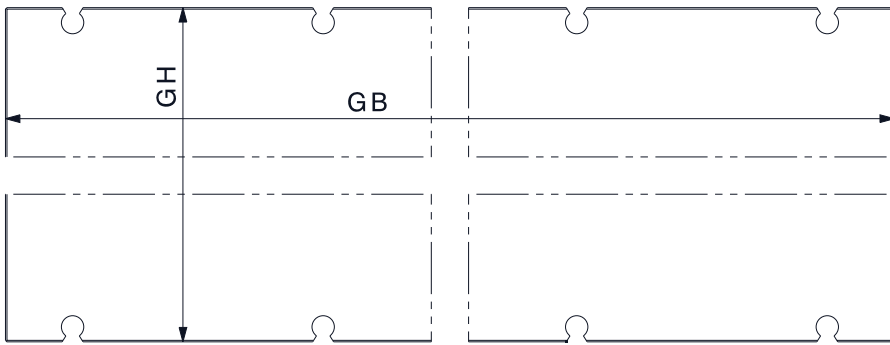

Technische Änderungen vorbehalten
 Sous réserve de modifications techniques
 Subject to modification

Con riserva di apportare modifiche tecniche
 Bajo reserva de modificaciones técnicas

Bestellung Glastüren
Commande des portes en verre
Order for glass doors
Ordinazione porte di vetro
Pedido de paneles de cristal

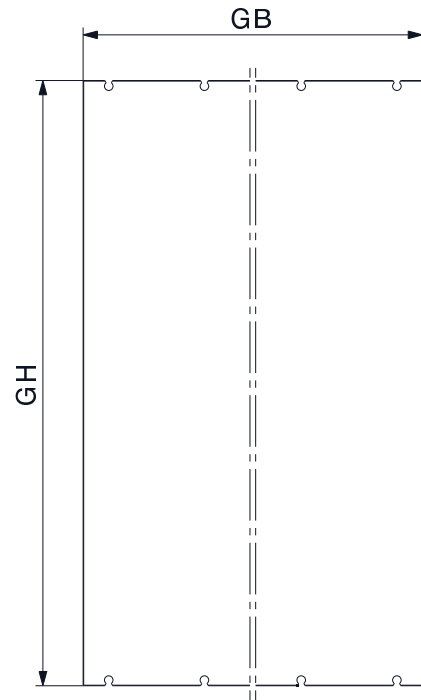
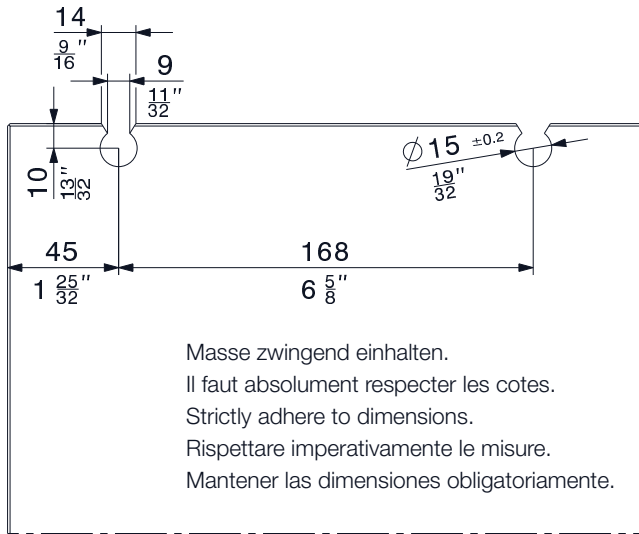

Alle Glaskanten gesäumt, im Glasausschnitt max. 1 mm.
 Ensemble des chants de verre bordés, 1 mm max. dans la découpe de verre.
 All-glass edges are seamed; maximum 1 mm in the glass cutout.
 Tutti i bordi vetro rifilati, nell'intaglio del vetro max. 1 mm.
 Cantear todos los cantos del cristal, en la muesca del cristal 1mm como máx.

Bezeichnung Désignation Designation Denominazione Designación	Anzahl Türen Nombre de portes Number of doors Numero porte Número de paneles	Glasbreite (GB) Largeur de glace (GB) Glass width (GB) Larghezza vetro (GB) Ancho del cristal (GB) DT = STB* = GB = STB - 4 DT - 4	Glashöhe (GH) Hauteur de glace (GH) Glass height (GH) Altezza vetro (GH) Altura del cristal (GH) STH* = GH = STH - 68
Anzahl Türen total Nombre de portes au total Total number of doors Numero porte totale Total número de paneles		ESG** Glasdicke = mm Epaisseur de glace (ESG**) = mm Glass thickness (ESG**) = mm ESG** spessore vetro = mm Espesor del cristal ESG** = mm	

* siehe Seite 6/7/10
 voir pages 6/7/10
 see pages 6/7/10
 vedi pagine 6/7/10
 ver páginas 6/7/10

ESG**
 Einscheibensicherheitsglas
 Verre de sécurité trempé
 Fully tempered monolithic glass
 Vetro singolo temperato di sicurezza
 Cristal monolitico

Komponenten Drehtüren
Composants des portes pivotantes
Components pivot doors
Componenti porte girevoli
Componentes puertas pivotantes

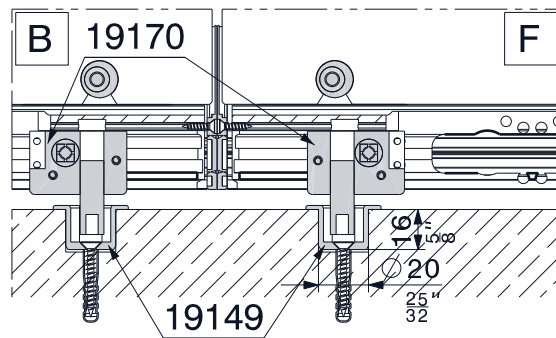
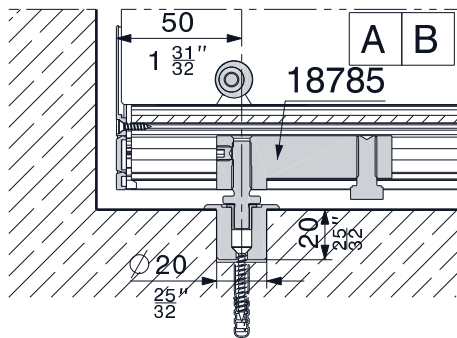
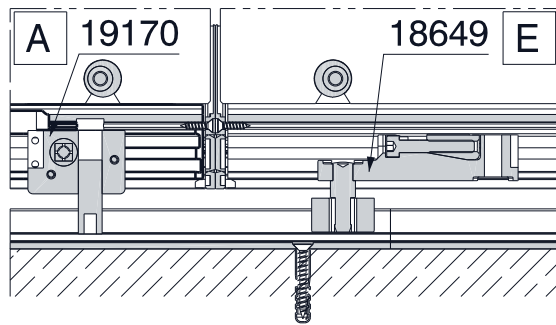
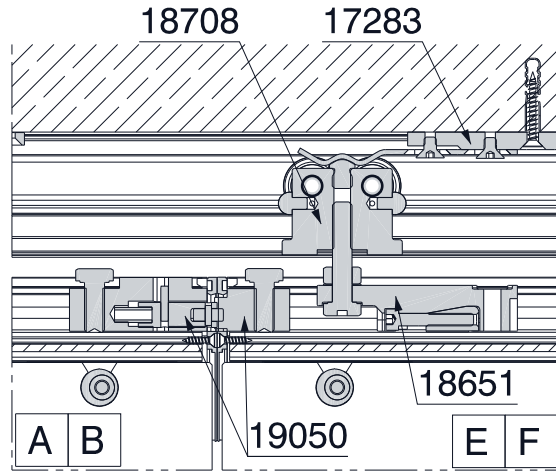
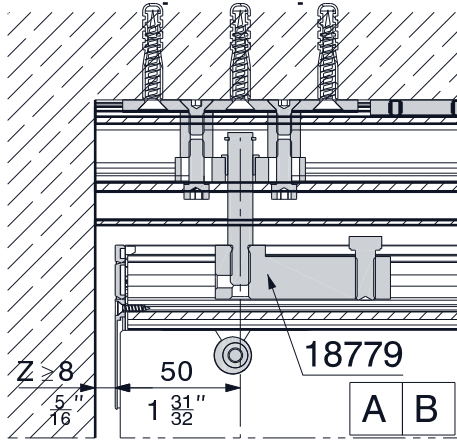

Technische Änderungen vorbehalten
 Sous réserve de modifications techniques
 Subject to modification

Con riserva di apportare modifiche tecniche
 Bajo reserva de modificaciones técnicas

Komponenten Schiebetüren
Composants des portes coulissantes
Components sliding doors
Componenti porte scorrevoli
Componentes paneles deslizantes

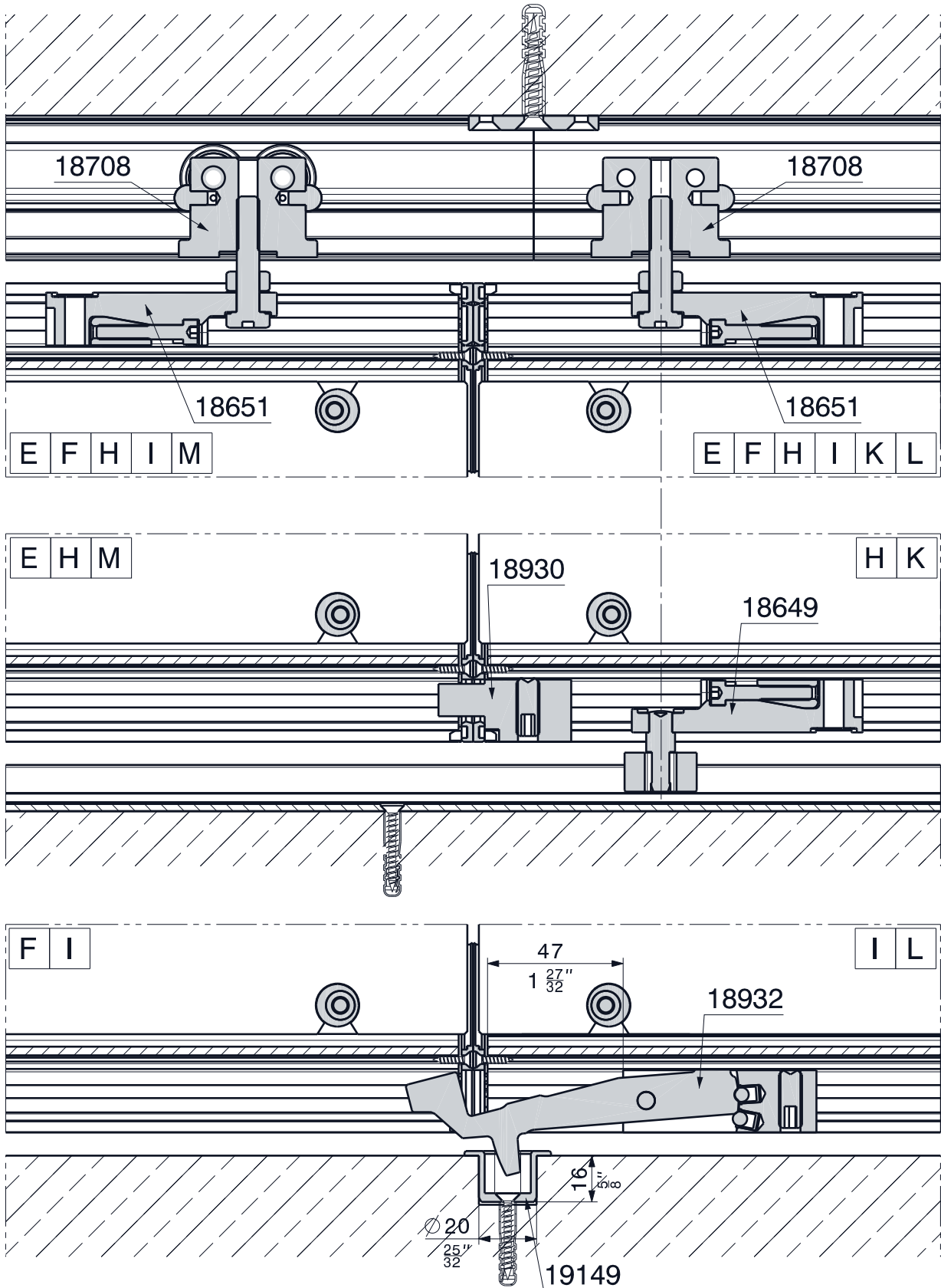

Komponenten Wandanschluss
Composantes de raccordement mural
Wall joint components
Componenti collegamento a parete
Componentes de fijación al muro

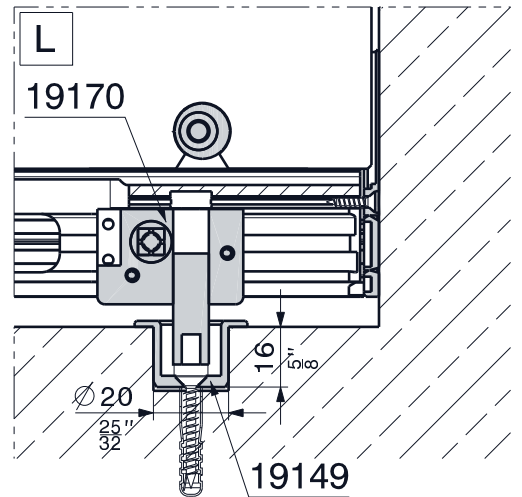
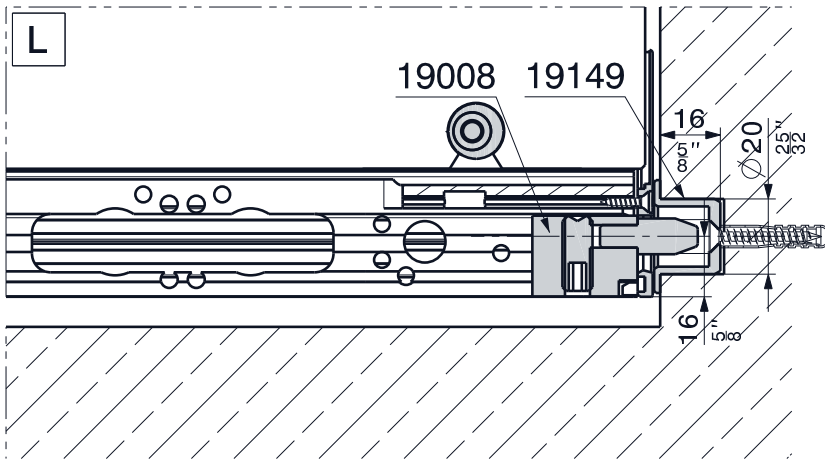
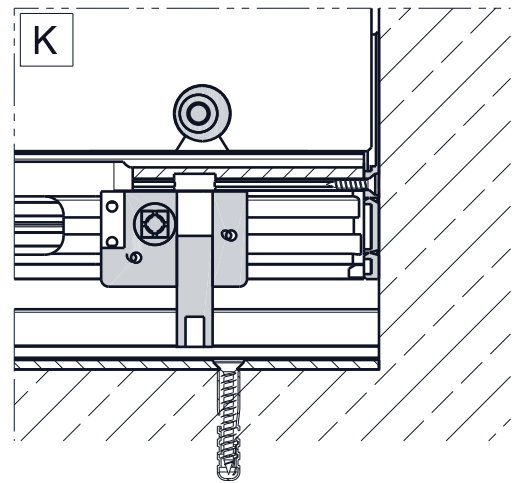
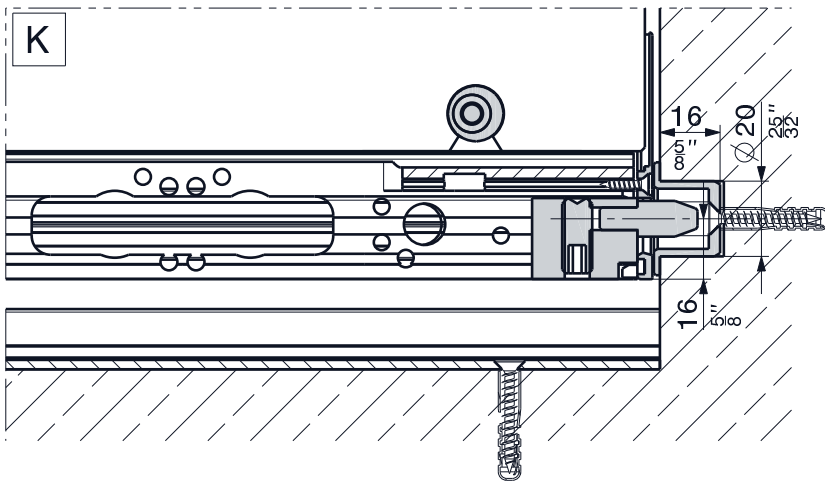
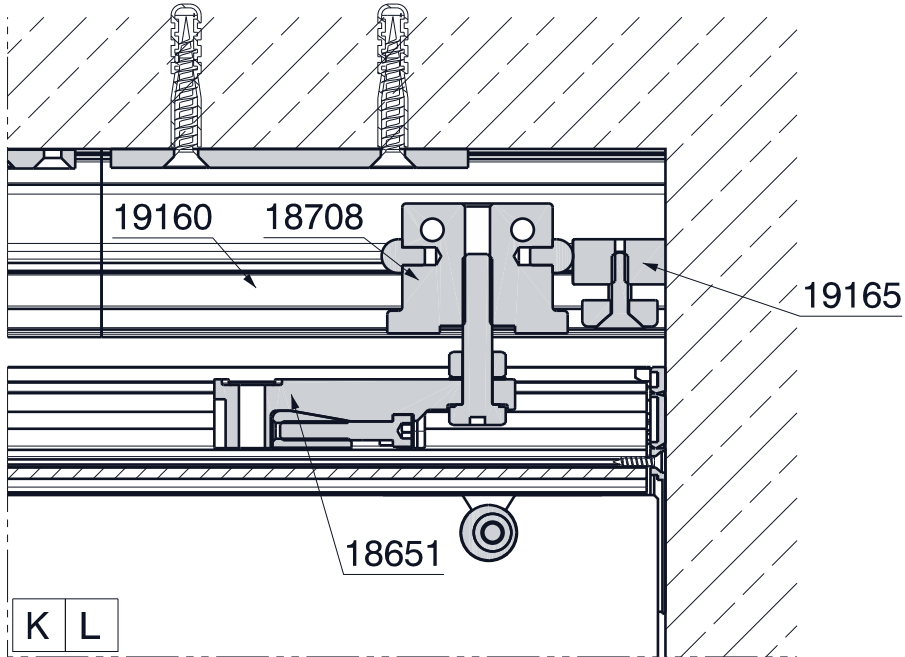

Montage Führungsschiene, Drucklager-Hülse und Schliesshülse
Montage des rails de guidage, douille de palier et douille de fermeture
Mounting of bottom guide channel, thrust bearing sleeve and sleeve closure
Montaggio guida, bussola cuscinetto reggispinta e bussola di chiusura
Montaje de los rieles de guía, casquillo embutido p. pivot inferior y casquillo p. cerraduras

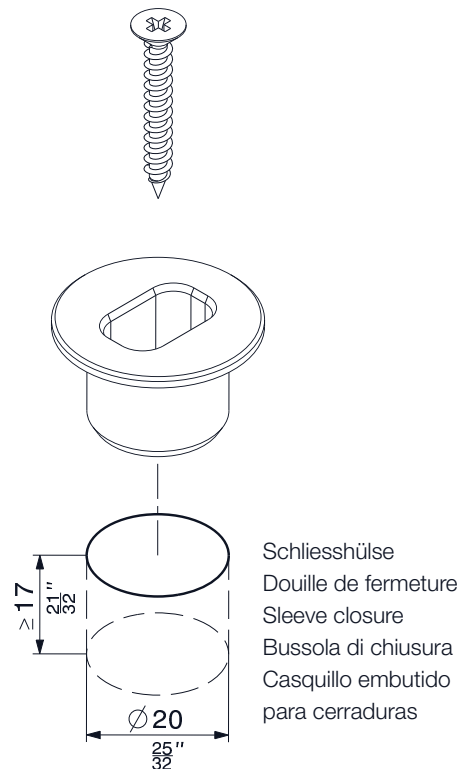
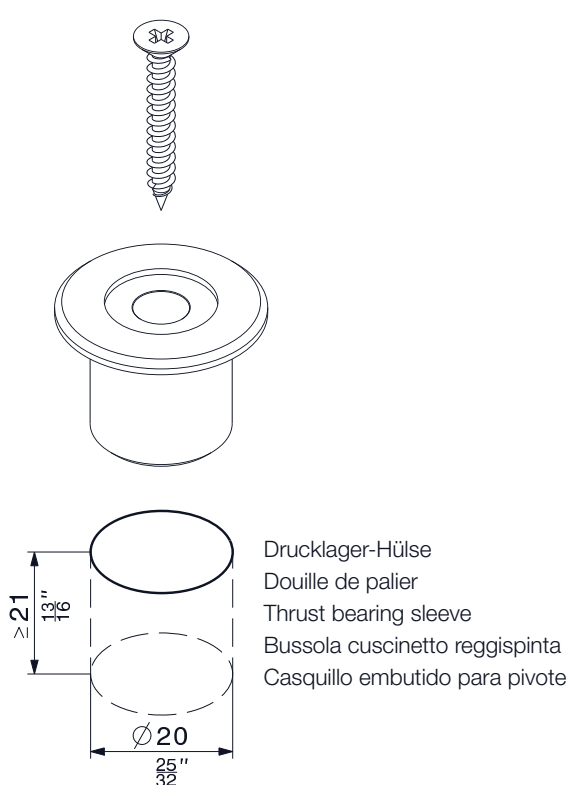
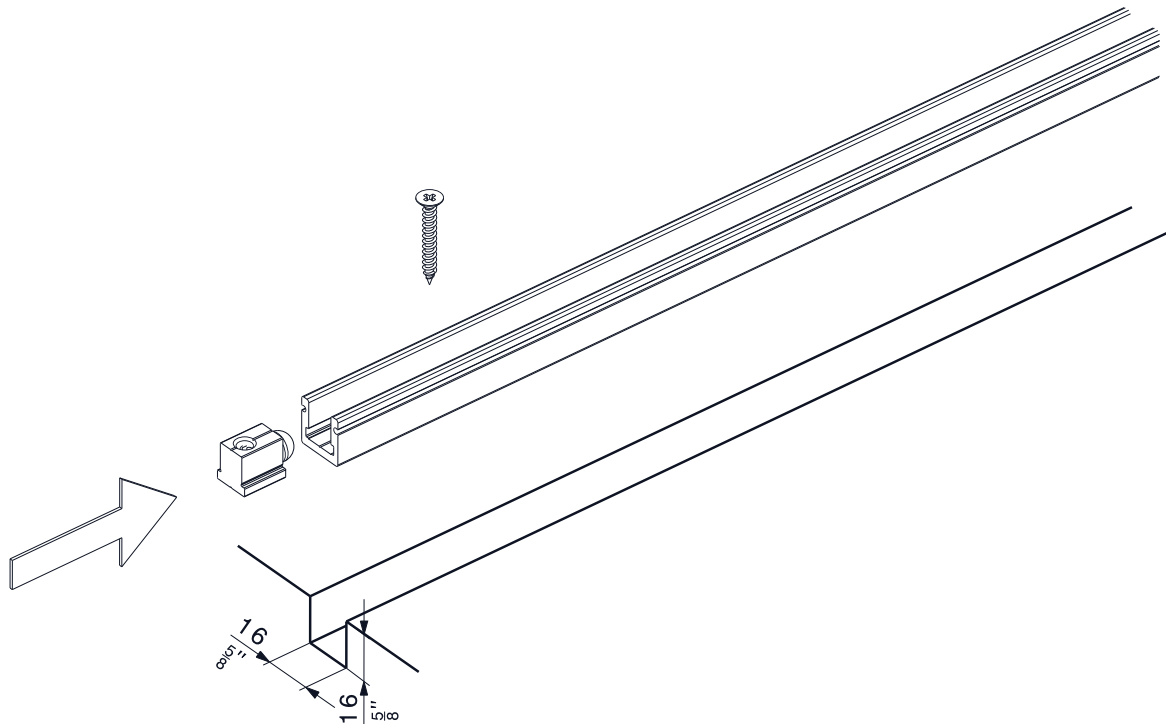

Montage der Laufschiene
Montage des rails de roulement
Mounting of top tracks
Montaggio dei binari
Montaje de los rieles de rodadura

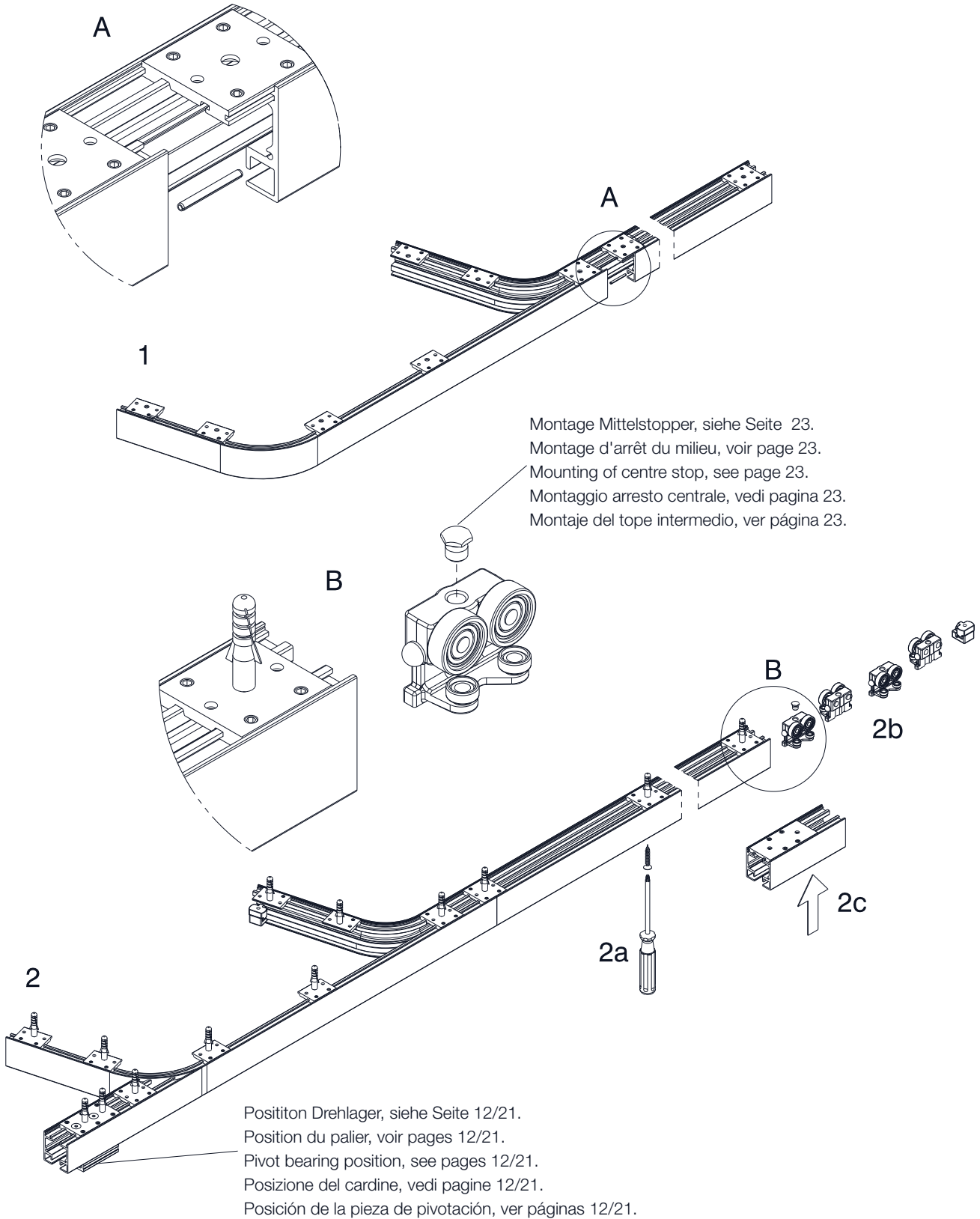

Technische Änderungen vorbehalten
 Sous réserve de modifications techniques
 Subject to modification

Con riserva di apportare modifiche tecniche
 Bajo reserva de modificaciones técnicas

Montage Stapelraum-Innenverblendung
Montage de cache intérieur pour espace de parcage
Mounting of the stacking area inside covers
Montaggio zona di stipa-rivestimento interno
Montaje del área de apilado con perfil de cobertura a la vista

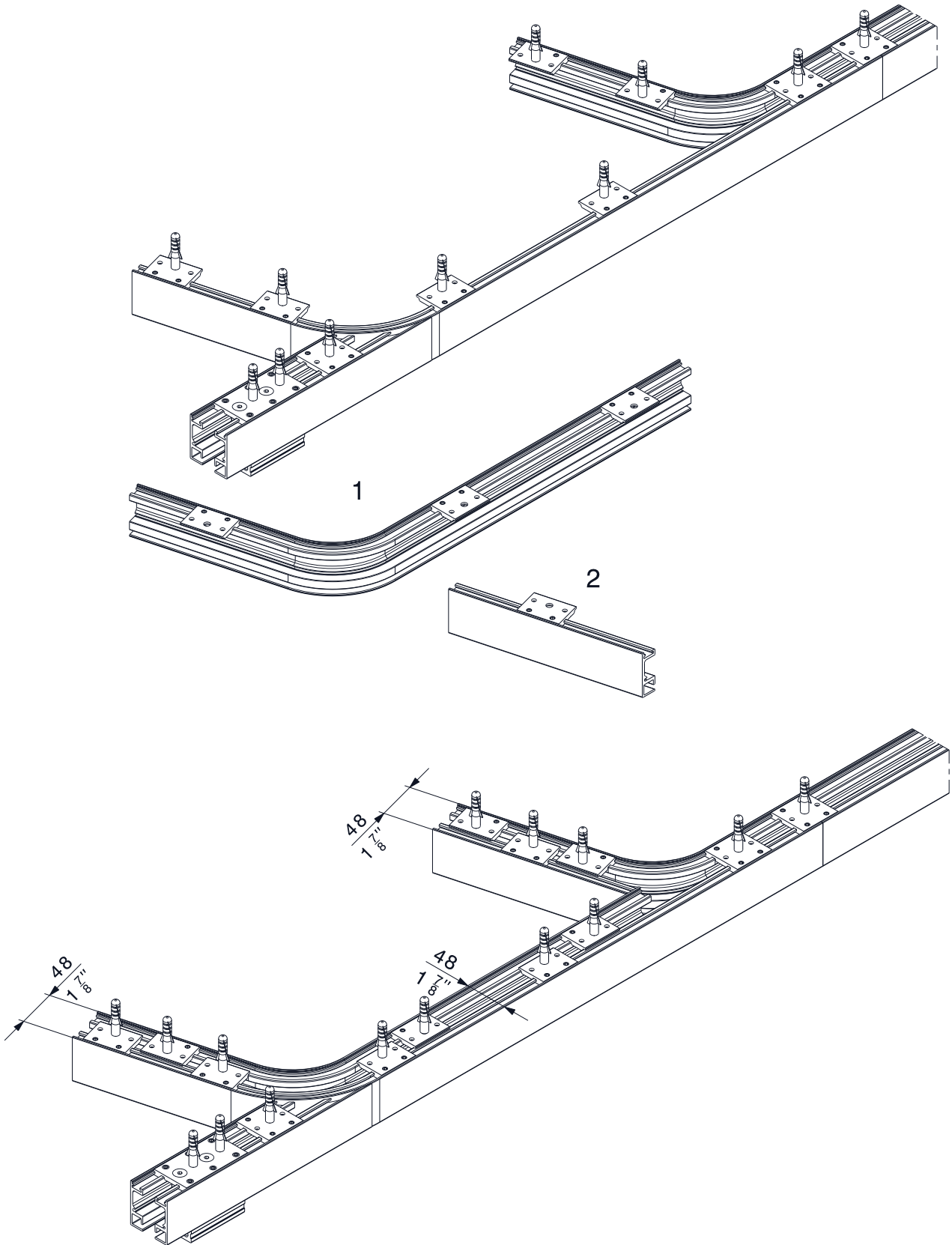

Technische Änderungen vorbehalten
Sous réserve de modifications techniques
Subject to modification

Con riserva di apportare modifiche tecniche
Bajo reserva de modificaciones técnicas

Position Glashalteprofil mit Schlossausfräsung
Position du profil porte-glace avec défonçage pour serrure
Position of glass retainer profile with lock cutout
Posizione profilo serravetro con fresatura serratura
Posición del perfil portacristal con fresado para cerradura

Mit Führungsschiene
 Avec rail de guidage
 With bottom guide channel
 Con guida
 Con riel de guía

Ohne Führungsschiene
 Sans rail de guidage
 Without bottom guide channel
 Senza guida
 Sin riel de guía

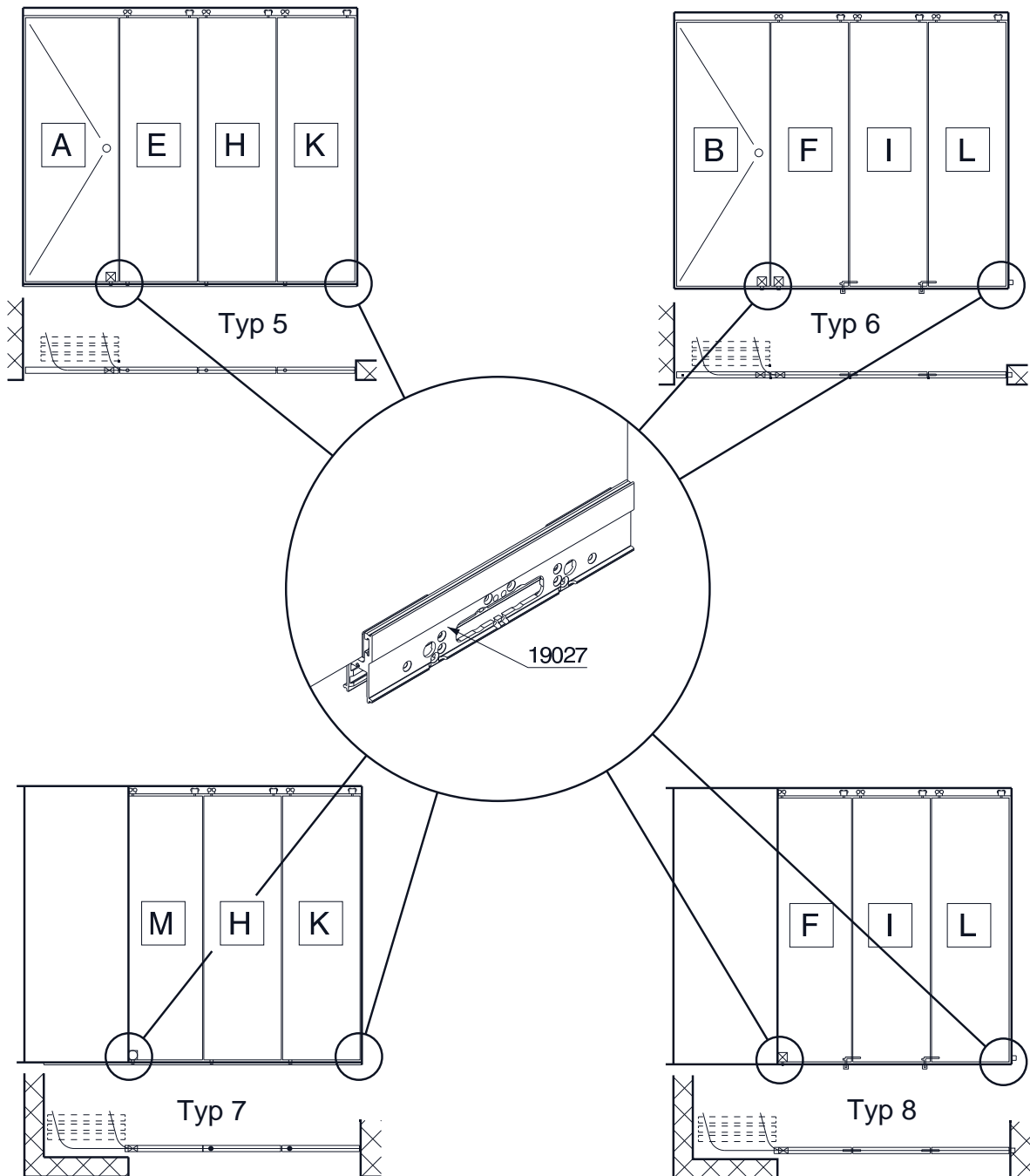

- Rundriegelschloss mit Führungszapfen
 Serrure à verrou rond avec goujon de guidage
 Round bar lock with guide pin
 Serratura a chiavistello tondo con perno di guida
 Pasador de varilla redonda con rodillo de guía

- ⊗ Rundriegelschloss
 Serrure à verrou rond
 Round bar lock
 Serratura a chiavistello tondo
 Pasador de varilla redonda

Montage Glashalteprofil
Montage du profil porte-glace
Mounting of glass retainer profile
Montaggio del profilo serravetro
Montaje del perfil portacristal

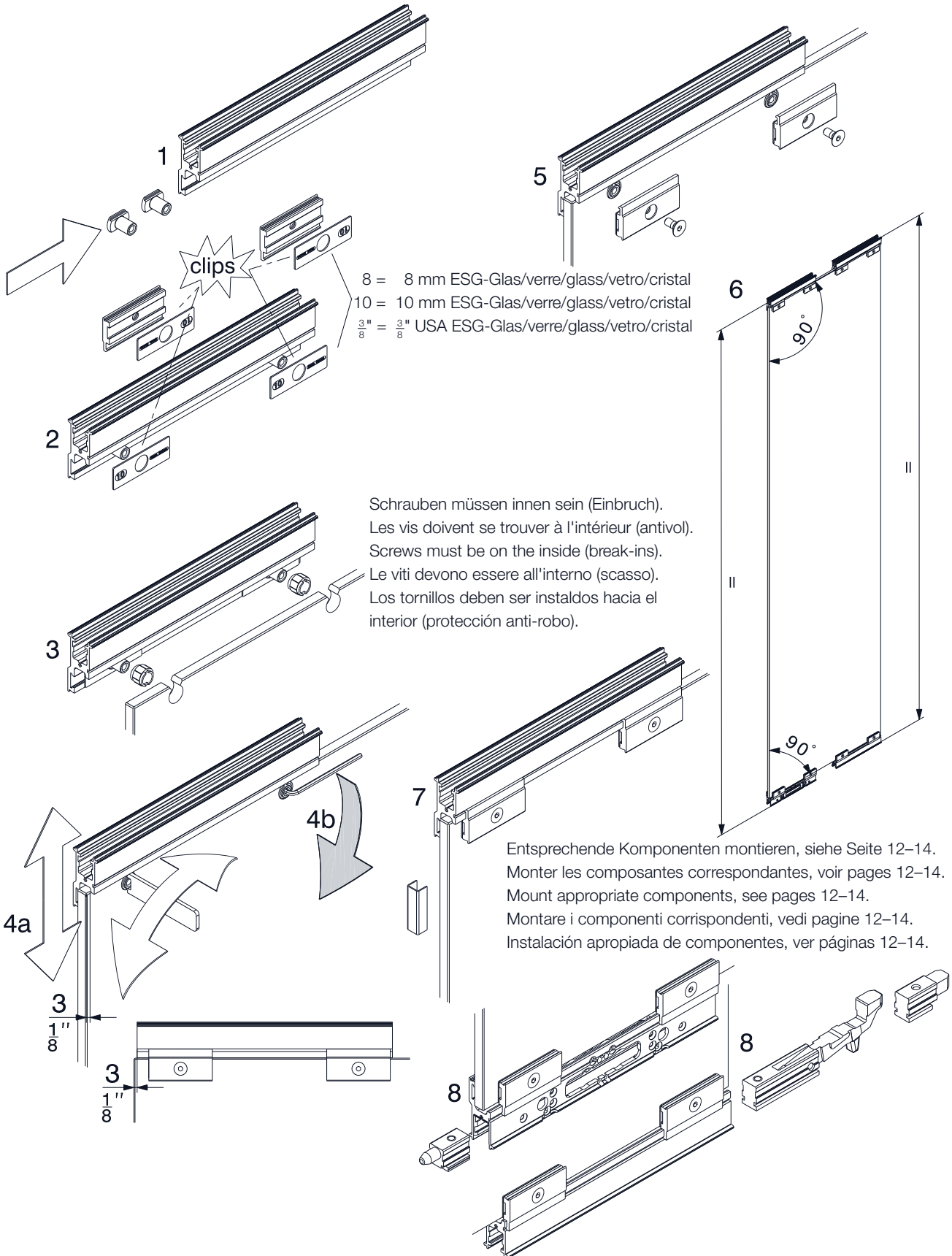

Montage von Rundriegelschloss mit Zylindermodul
Montage de la serrure à verrou rond avec bloc cylindre
Mounting of round bar lock with cylinder module
Montaggio della serratura a chiavistello tondo con modulo cilindro
Montaje cerradura de vástago redondo con módulo de cilindro

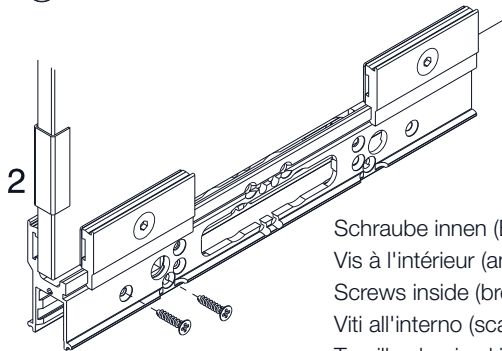
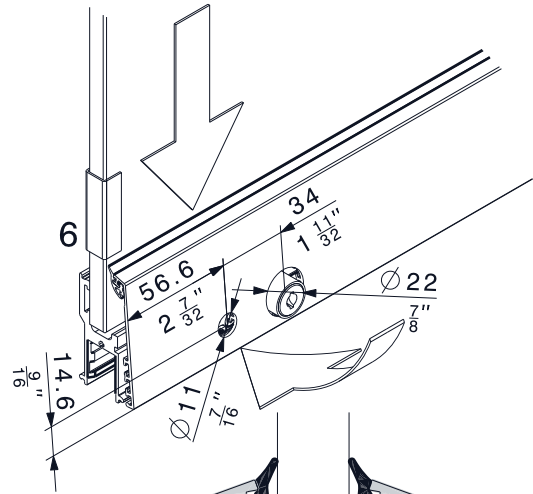
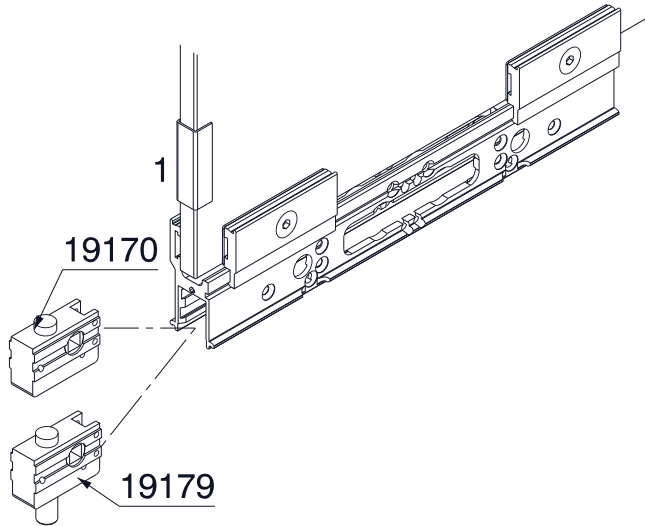

Schraube innen (Einbruch).
 Vis à l'intérieur (antivol).
 Screws inside (break-ins).
 Viti all'interno (scasso).
 Tornillos hacia al interior (protección anti-rob).
 14.6
9/16

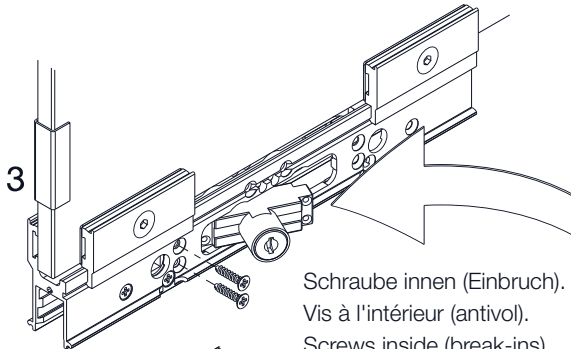
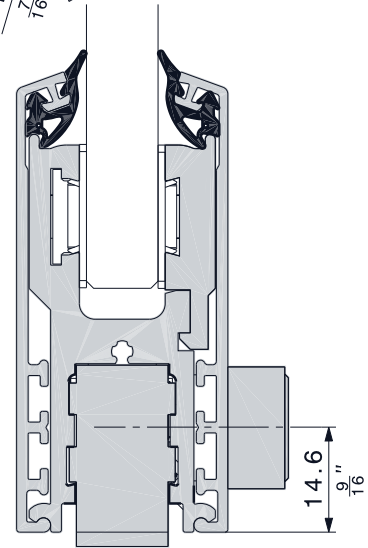

Schraube innen (Einbruch).
 Vis à l'intérieur (antivol).
 Screws inside (break-ins).
 Viti all'interno (scasso).
 Tornillos hacia al interior.



mit Glasreiniger
 avec nettoyeur de verre
 with glass cleaner
 con pulitura da vetri
 con limpiavidrios

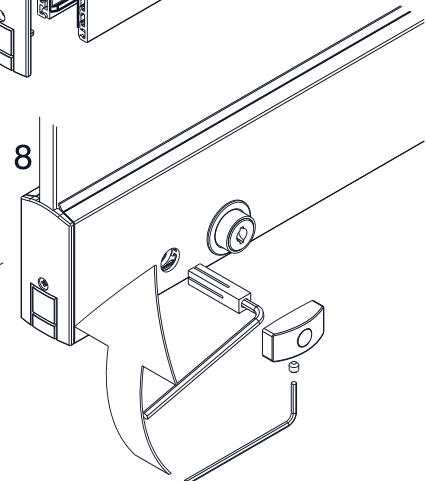
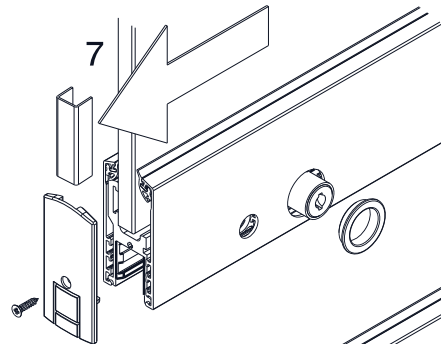
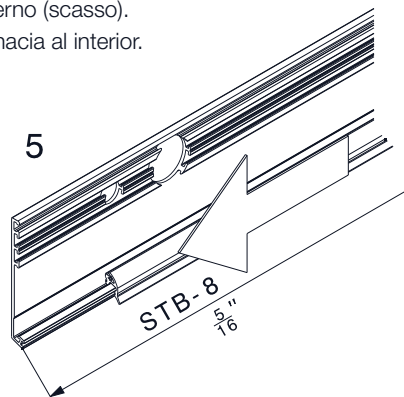

*Montage der Drehtüre
 Montage de la porte pivotante
 Mounting of pivot door
 Montaggio della porta girevole
 Montaje de la puerta pivotante*

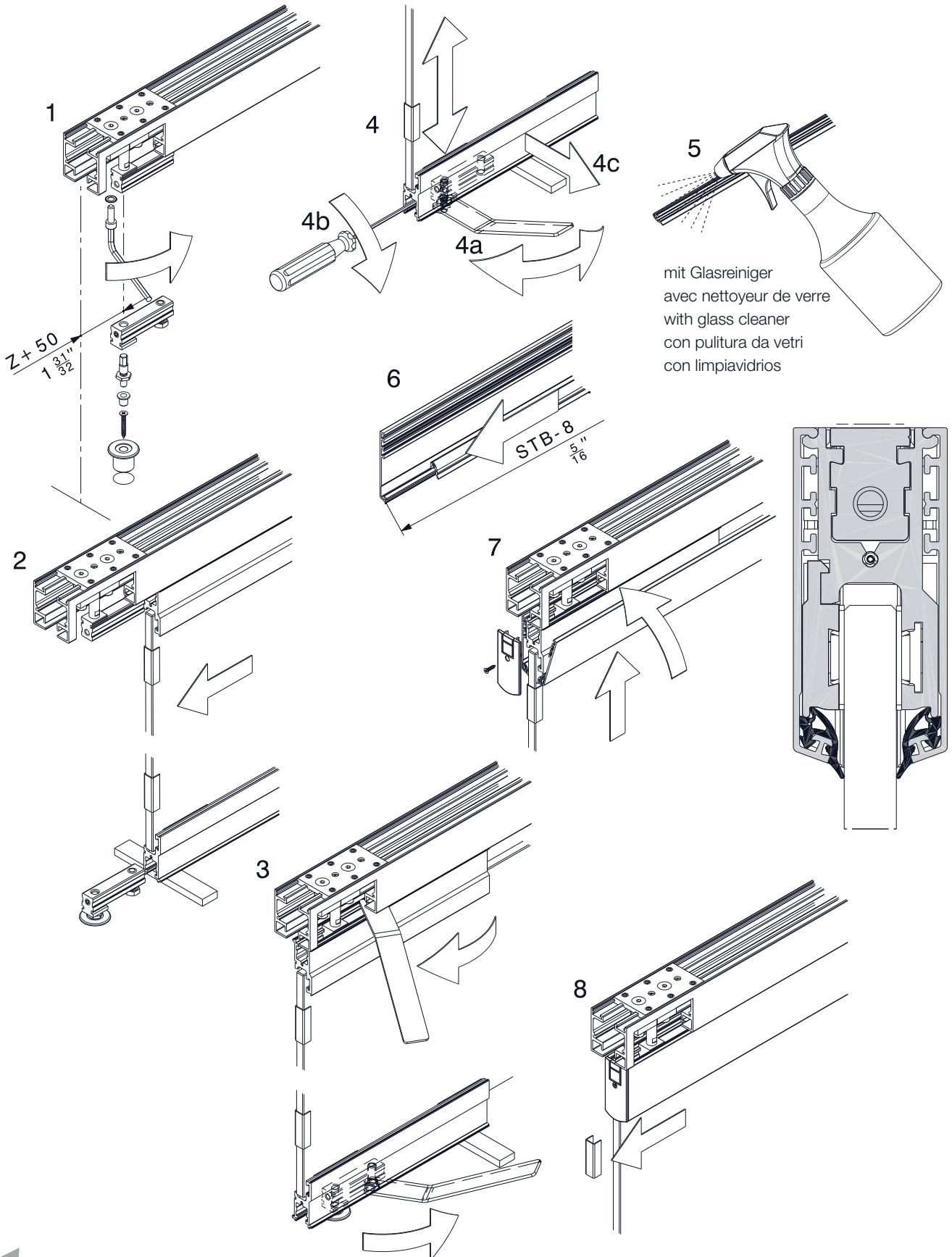

Montage der Schiebetüre
Montage de la porte coulissante
Mounting of sliding door
Montaggio della porta scorrevole
Montaje del panel deslizante

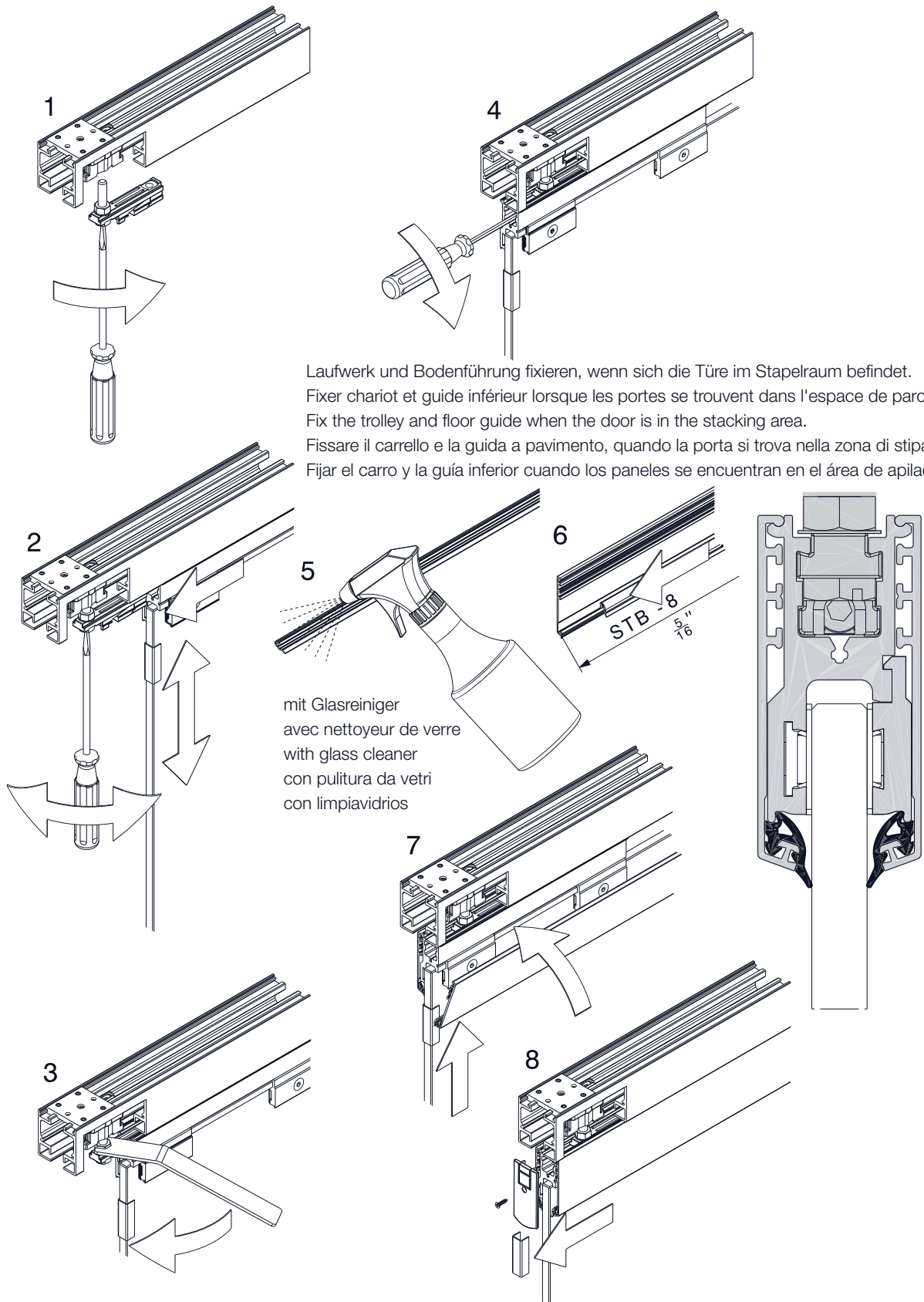

Laufwerk und Bodenführung fixieren, wenn sich die Türe im Stapelraum befindet.
 Fixer chariot et guide inférieur lorsque les portes se trouvent dans l'espace de parcage.
 Fix the trolley and floor guide when the door is in the stacking area.
 Fissare il carrello e la guida a pavimento, quando la porta si trova nella zona di stipa.
 Fijar el carro y la guía inferior cuando los paneles se encuentran en el área de apilado.

mit Glasreiniger
 avec nettoyeur de verre
 with glass cleaner
 con pulitura da vetri
 con limpiavidrios



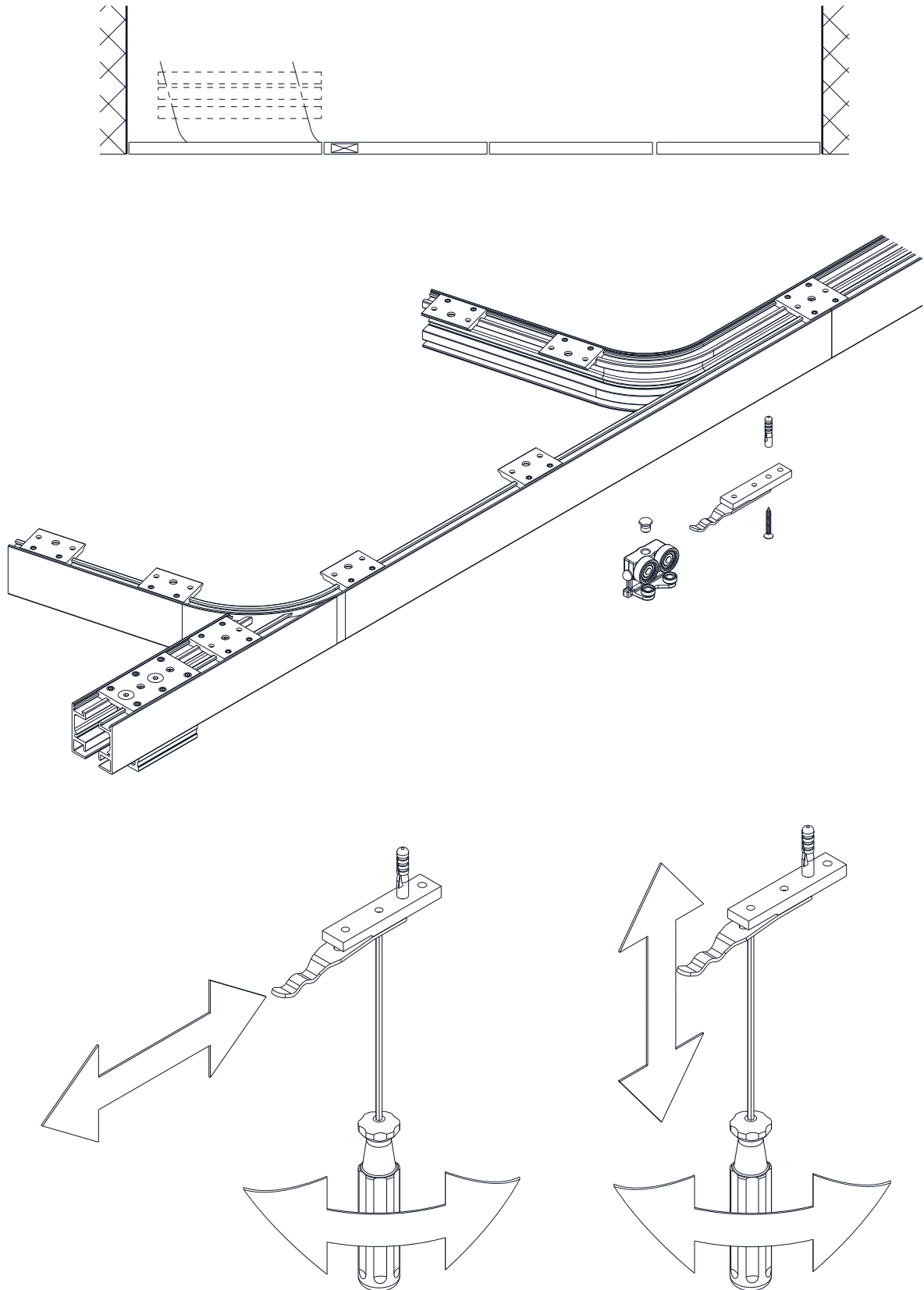



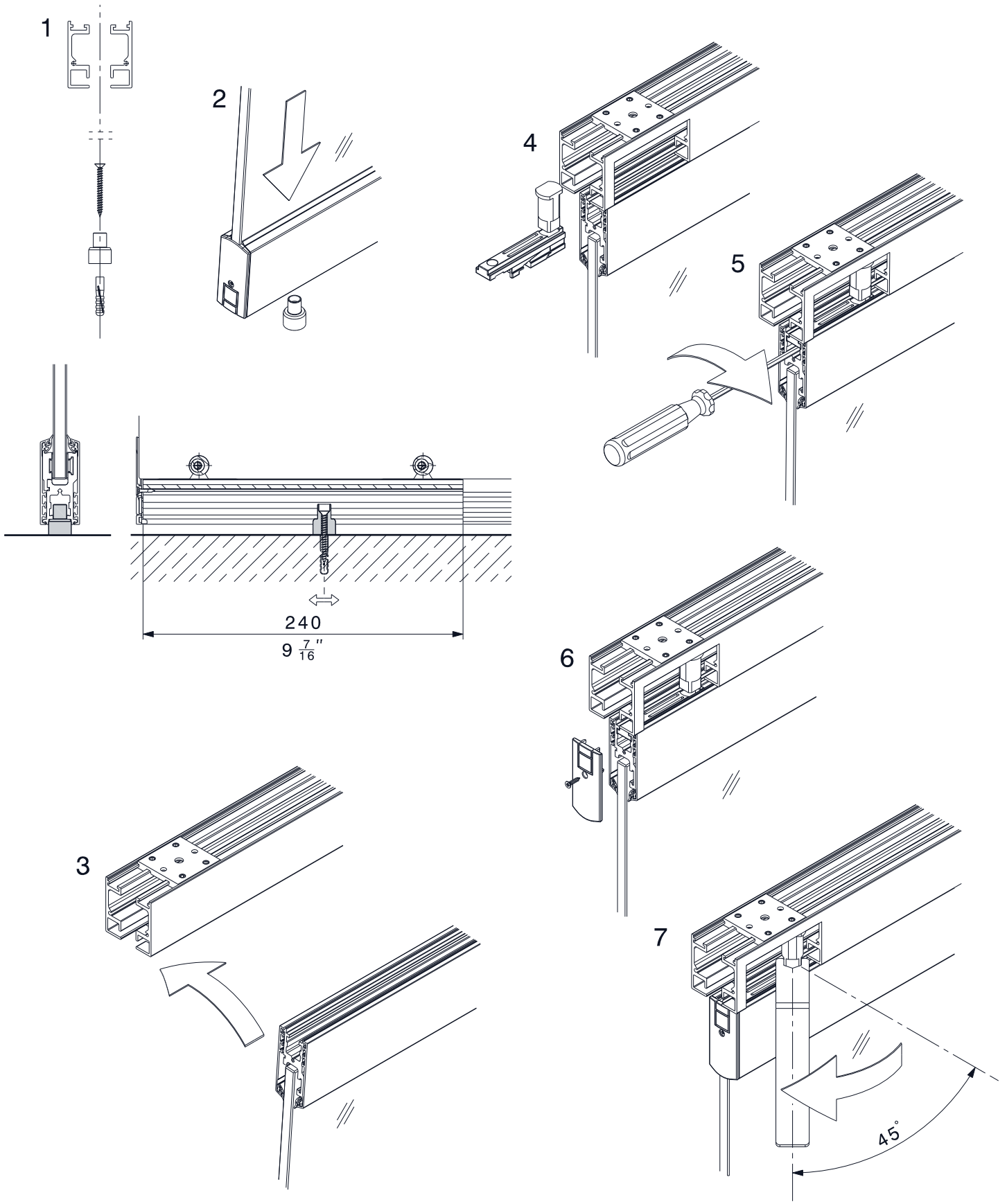



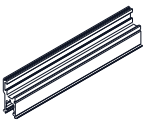
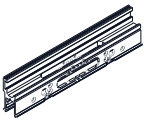

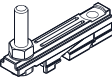

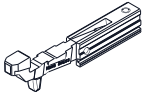

Montage Mittelstopper
Montage d'arrêt du milieu
Mounting of centre stop
Montaggio arresto centrale
Montaje del dispositivo de retención intermedio





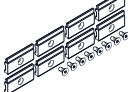



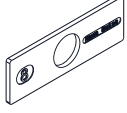

Montage Festverglasung
Montage glace fixe
Mounting of stationary glass
Montaggio vetrata fissa
Montaje del cristal fijo

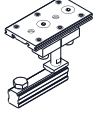







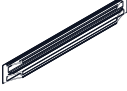
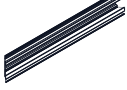

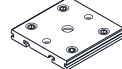
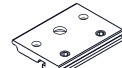

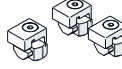

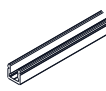
Beschlägeübersicht
Composants de la ferrure
Hardware system components
Assortimento ferramenta
Componentes de los herrajes

	19026
	19027
	18708
	18651
	18751
	18649
	18932
	18930
	19008
	19149
	19170
	19179
	19174
	19107
	19264
	19265
	19266
	19256
	19128

	8 mm ($\frac{5}{16}$) Glas, verre, glass, vetro, cristal	19269
	10 mm ($\frac{12}{32}$) Glas, verre, glass, vetro, cristal	19270
	$\frac{3}{8}$ " Glas, verre, glass, vetro, cristal	19271
		19267
		18779
		18785
		19050

	2500 mm ($8'2 \frac{7}{16}$ ")	17795
	3500 mm ($11'5 \frac{13}{16}$ ")	17796
	6000 mm ($19'8 \frac{7}{32}$ ")	16891
	nach Mass sur mesure cut to size su misura a medida	17529
		17289
		17290
		19160
		18804
		19144

		17128
		17749
		17221
		19165
		17283
	3500 mm ($11'5 \frac{13}{16}$ ")	18864
	6000 mm ($19'8 \frac{7}{32}$ ")	18216
	nach Mass sur mesure cut to size su misura a medida	18477
		18748
		18640
		18652
	800 mm ($2'7 \frac{1}{2}$ ")	19222
	1000 mm ($3'3 \frac{3}{8}$ ")	19223
	1200 mm ($3'11 \frac{1}{4}$ ")	19224
1 x uneloxiert non anodisé unanodized non anodizzato sin anodizar	800 mm ($2'7 \frac{1}{2}$ ")	19167
	1000 mm ($3'3 \frac{3}{8}$ ")	19168
	1200 mm ($3'11 \frac{1}{4}$ ")	19169
farblos eloxiert anodisé incolore plain anodized anodizzato incolore anodizado plato	800 mm ($2'7 \frac{1}{2}$ ")	19176
	1000 mm ($3'3 \frac{3}{8}$ ")	19177
	1200 mm ($3'11 \frac{1}{4}$ ")	19178
Edelstahl-Effekt imitation inox stainless-steel effect effetto acciaio inox efecto acero inoxid.	800 mm ($2'7 \frac{1}{2}$ ")	19176
	1000 mm ($3'3 \frac{3}{8}$ ")	19177
	1200 mm ($3'11 \frac{1}{4}$ ")	19178
		19175
		19714
		19715