

Garnituren / Sets / Garnitures

Bei 2 Türen 1 Garnitur bestellen
For 2 doors please order 1 set
Pour 2 portes a commander 1 garniture

No. 055.3124.071

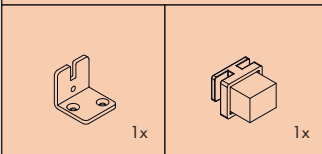

Bei 2 Türen 2 Garnituren bestellen
For 2 doors please order 2 sets
Pour 2 portes a commander 2 garnitures

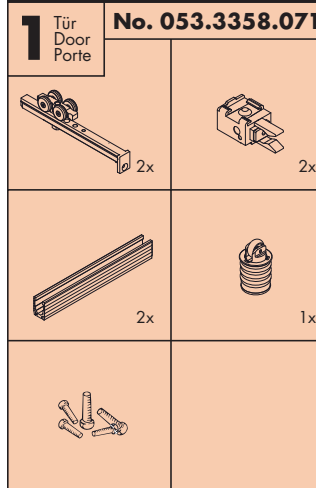

Zubehör / Accessories / Accessoires

A Einfachlaufschiene, Alu eloxiert, zum Kleben

Single running track, aluminium anodized, for glue fixing
Rail de roulement simple, en alu anodisé, à coller

Gr./Size

2500 mm

3500 mm

6000 mm

Art. No.

053.3324.250

053.3324.350

053.3324.600

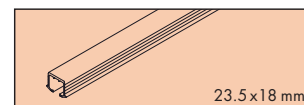

B Einfachlaufschiene, Alu eloxiert, mit Drehriegel

Single running track, aluminium anodized, with swivel lug
Rail de roulement simple, en alu anodisé, avec verrou

2500 mm

3500 mm

6000 mm

053.3327.250

053.3327.350

053.3327.600

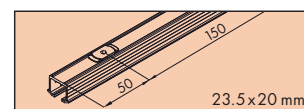

C Einfachlaufschiene, Alu eloxiert, gelocht, zum Schrauben

Single running track, aluminium anodized, pre-drilled, for screw fixing
Rail de roulement simple, en alu anodisé, perforé, à visser

2500 mm

3500 mm

6000 mm

053.3325.250

053.3325.350

053.3325.600

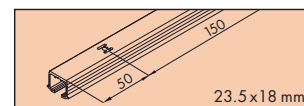

Schienenendstück zu 053.3324/3325/3327, mit Drehriegel

Track end piece for 053.3324/3325/3327, with swivel lug
Pièce d'extrémité pour 053.3324/3325/3327, avec verrou

2 x

053.3355.051

(nicht für Hartholz/MDF, not for hard wood/MDF, pas pour bois dur/MDF)

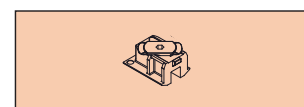

Schienenendstück zu 053.3324/3325/3327, Kunststoff grau

Track end piece for 053.3324/3325/3327, plastic grey

Pièce d'extrémité pour 053.3324/3325/3327, plastique gris

2 x

053.3354.071

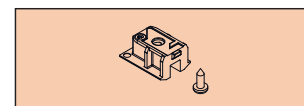

D Einfachlaufschiene, Alu eloxiert, gelocht, zum Schrauben

Single running track, aluminium anodized, pre-drilled, for screw fixing
Rail de roulement simple, en alu anodisé, perforé, à visser

2500 mm

3500 mm

6000 mm

053.3341.250

053.3341.350

053.3341.600

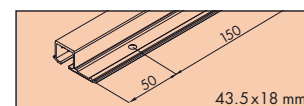

E Doppellaufschiene, Alu eloxiert, gelocht, zum Schrauben

Double running track, aluminium anodized, pre-drilled, for screw fixing
Rail de roulement double, en alu anodisé, perforé, à visser

2500 mm

3500 mm

6000 mm

053.3328.250

053.3328.350

053.3328.600

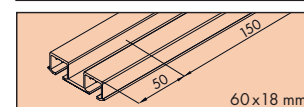

F Doppellaufschiene, Alu eloxiert, gelocht, zum Aufschrauben

Double running track, aluminium anodized, pre-drilled, surface mounted
Rail de roulement double, en alu anodisé, perforé, à visser en applique

2500 mm

3500 mm

6000 mm

053.3339.250

053.3339.350

053.3339.600

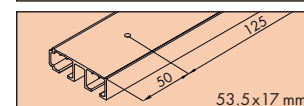

Führungsschiene, Alu, ungelocht, zum Kleben

Guide track, aluminium, not pre-drilled, for glue fixing

Rail de guidage, en alu, non perforé, à coller

2500 mm

3500 mm

6000 mm

053.3074.250

053.3074.350

053.3074.600

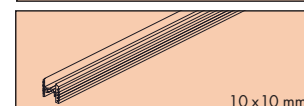

A Werkzeug | Tool | Outil

- ⊕ PZ: 1/2
- ⊙ SW: 3/4
- ⊗ TX: 8
- ⊖ No.: 0
- ⊕ SW: 8

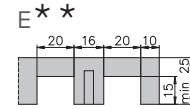
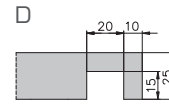
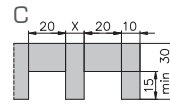
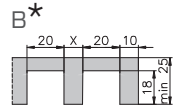
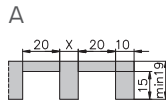
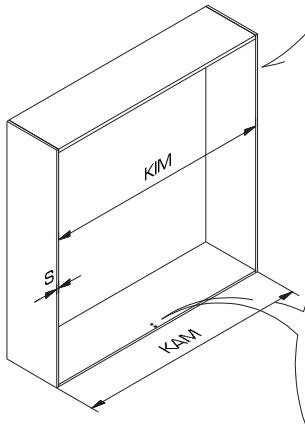

* Nicht für Hartholz/MDF
Not for hard wood/MDF
Pas pour bois dur/MDF

** Nur für 25mm Türen
25mm doors only
seulement pour
portes 25mm

*** Nur für 19mm Türen
19mm doors only
seulement pour
portes 19mm

	25 mm Türen / doors / portes	19 mm Türen / doors / portes
X	16 mm	10 mm
Y	36 mm	30 mm

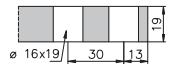
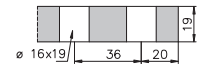
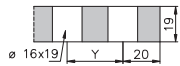
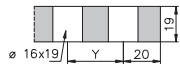
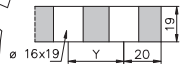

Befestigungsvarianten A - F / Mounting options A - F / Variantes de fixation A - F: 4

B



- 0 Stk.: X = 1 mm
- 1 Stk.: X = 32 mm
- 2 Stk.: X = 64 mm

Optional / Optional / Optionnel
Variante E

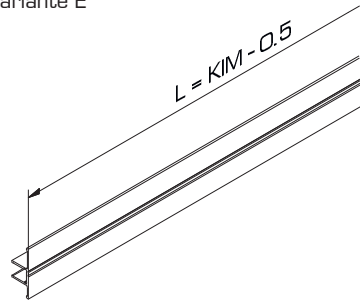

= D - G

A



B

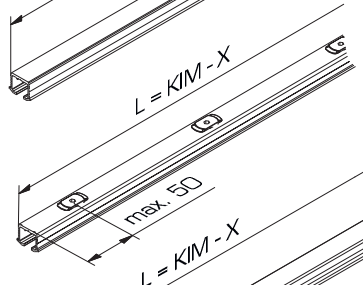

C

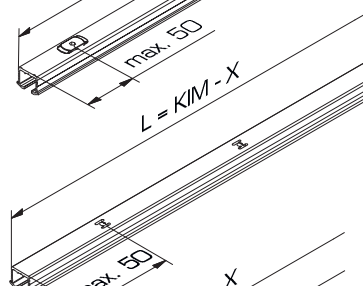

D

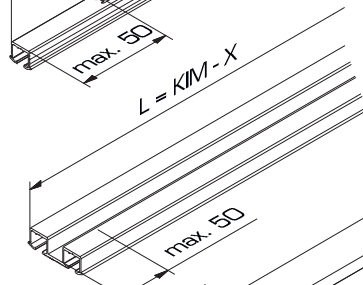

E

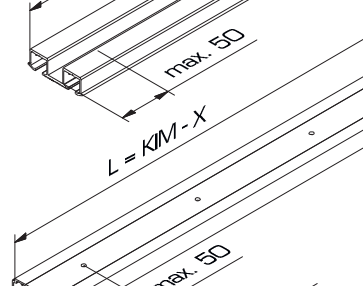

C

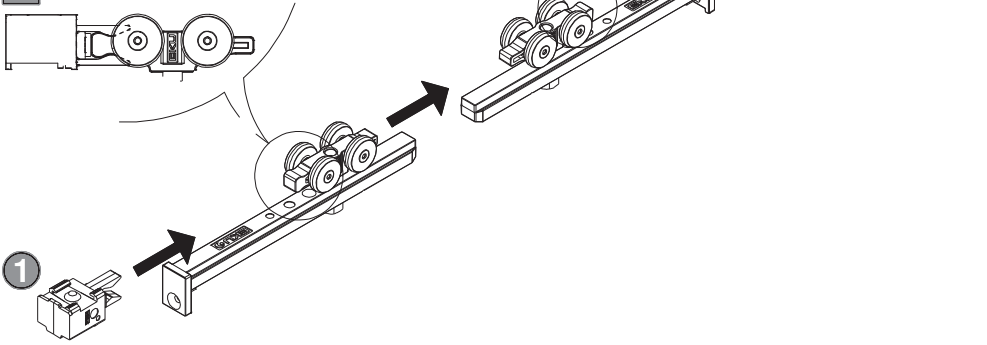

2

X = 7 mm	X = 39 mm
Y = 39 mm	Y = 71 mm

⊙ SW 3

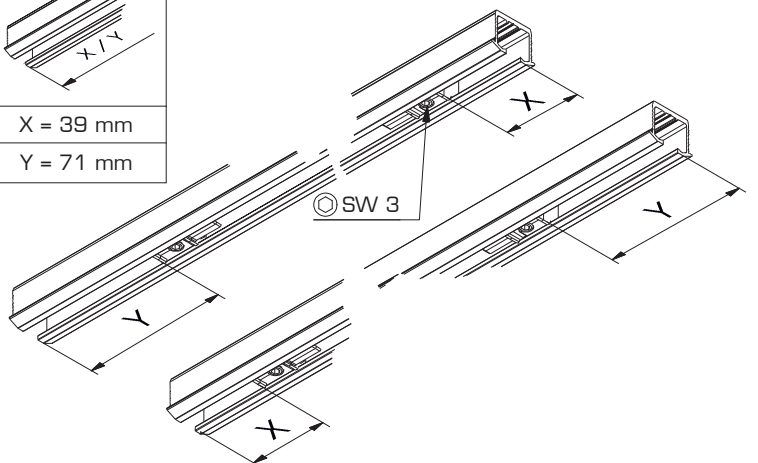

TB = 7

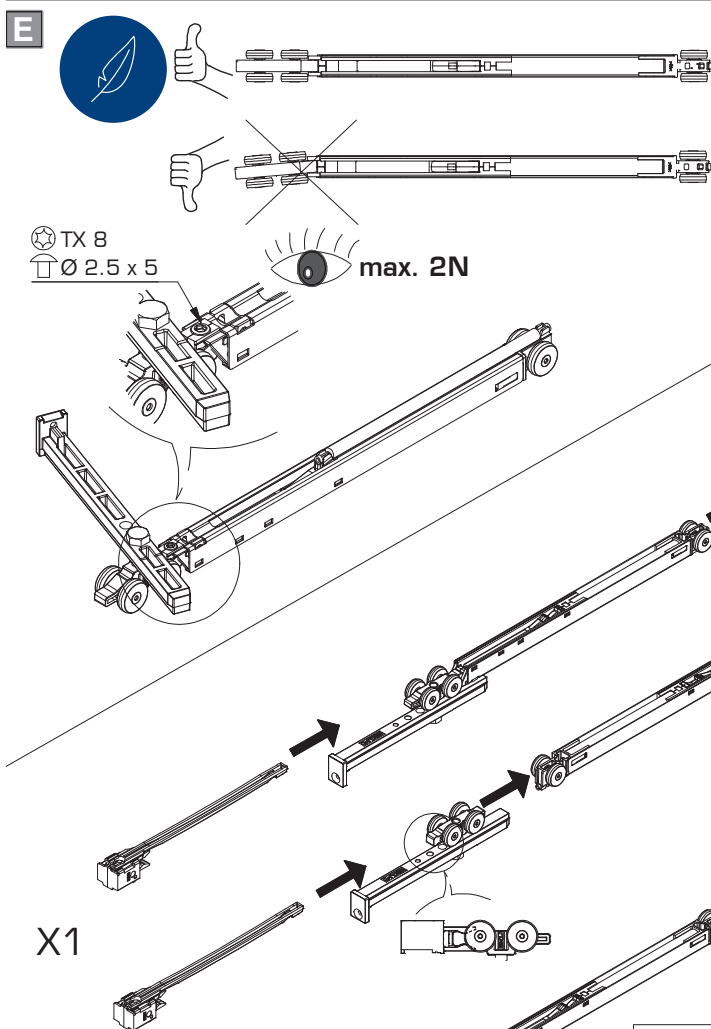
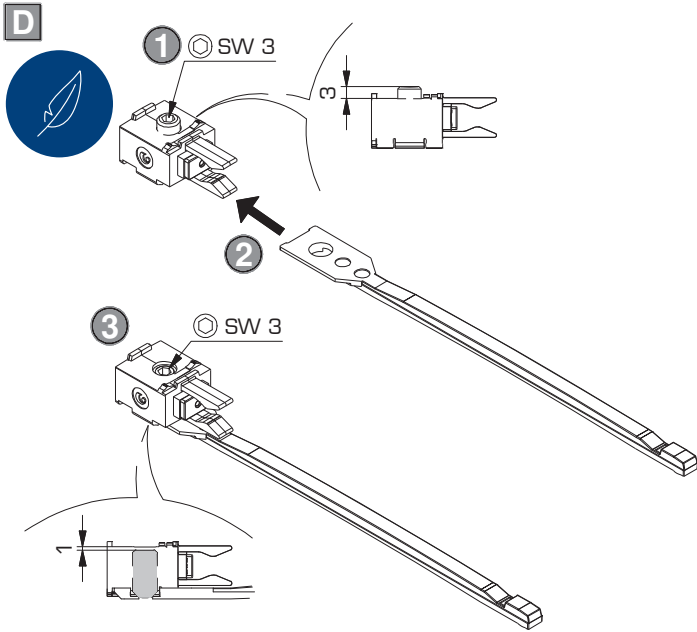

F

Garnituren / Sets / Garnitures
No. 057.3159.XXX

	2x
	2x
	2x

Empfehlung: Der Zugang zu den Dämpfungskomponenten sollte jederzeit möglich sein. Demontierbare Laufschienen oder Möbelkonstruktion entsprechend planen.

Recommendation: The access to soft-closing components should be possible at any time. Plan removable running tracks or furniture designs accordingly.

Recommandation: L'accès aux composants de l'amortisseur doit être possible é tout moment. Prévoir en conséquence des rails de roulement ou une constructions de meuble démontables.

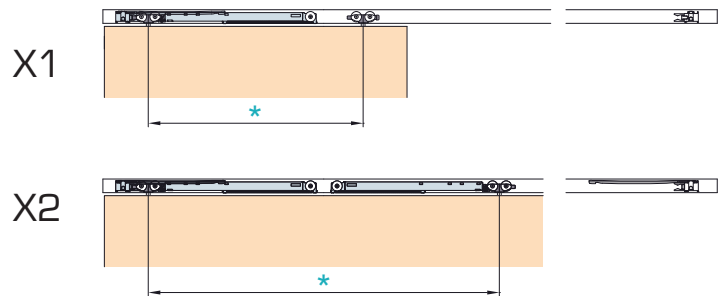

X1

X2

X1

X2

	*	Garnituren/Sets/Garnitures									
		1 Tür/Door/Porte			2 Türen/Doors/Porties			3 Türen/Doors/Porties			
		057.3159.*XXX			057.3159.*XXX			057.3159.*XXX			
	*071	*072	*073	*071	*072	*073	*071	*072	*073		
		-15 kg	-26 kg	-36 kg	-15 kg	-26 kg	-36 kg	-15 kg	-26 kg	-36 kg	
Dämpfen in Schliessrichtung Soft closing function in closing direction Amortissement dans le sens de fermeture	min. 260mm				1x	1x	1x	2x	2x	2x	X x Bestellen Order X x Commander X x
Dämpfen in Schliess- und Öffnungsrichtung Soft closing function in opening and closing direction Amortissement dans le sens de fermeture et d'ouverture	min. 460mm	1x	1x	1x	2x	2x	2x	2x	2x	2x	X x Bestellen Order X x Commander X x

G

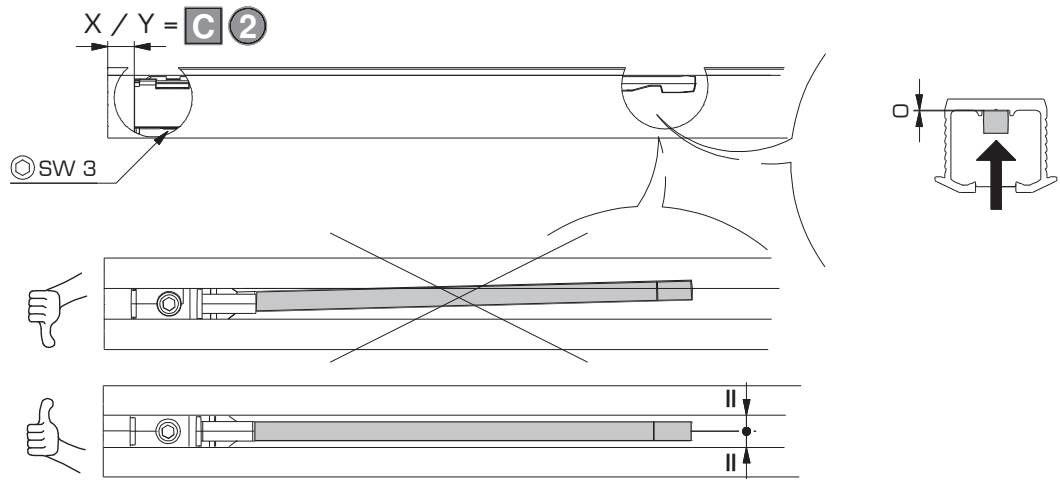

H

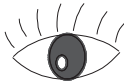

★ **Nicht für Hartholz/MDF**
Not for hard wood/MDF
Pas pour bois dur/MDF

Art. No. 053.3355.051 (VE = 2)

A / B / C = **Hartholz/MDF** - Hard wood/MDF - Bois dur/MDF = min. 30mm
Art. No. 053.3354.071 (VE = 2)

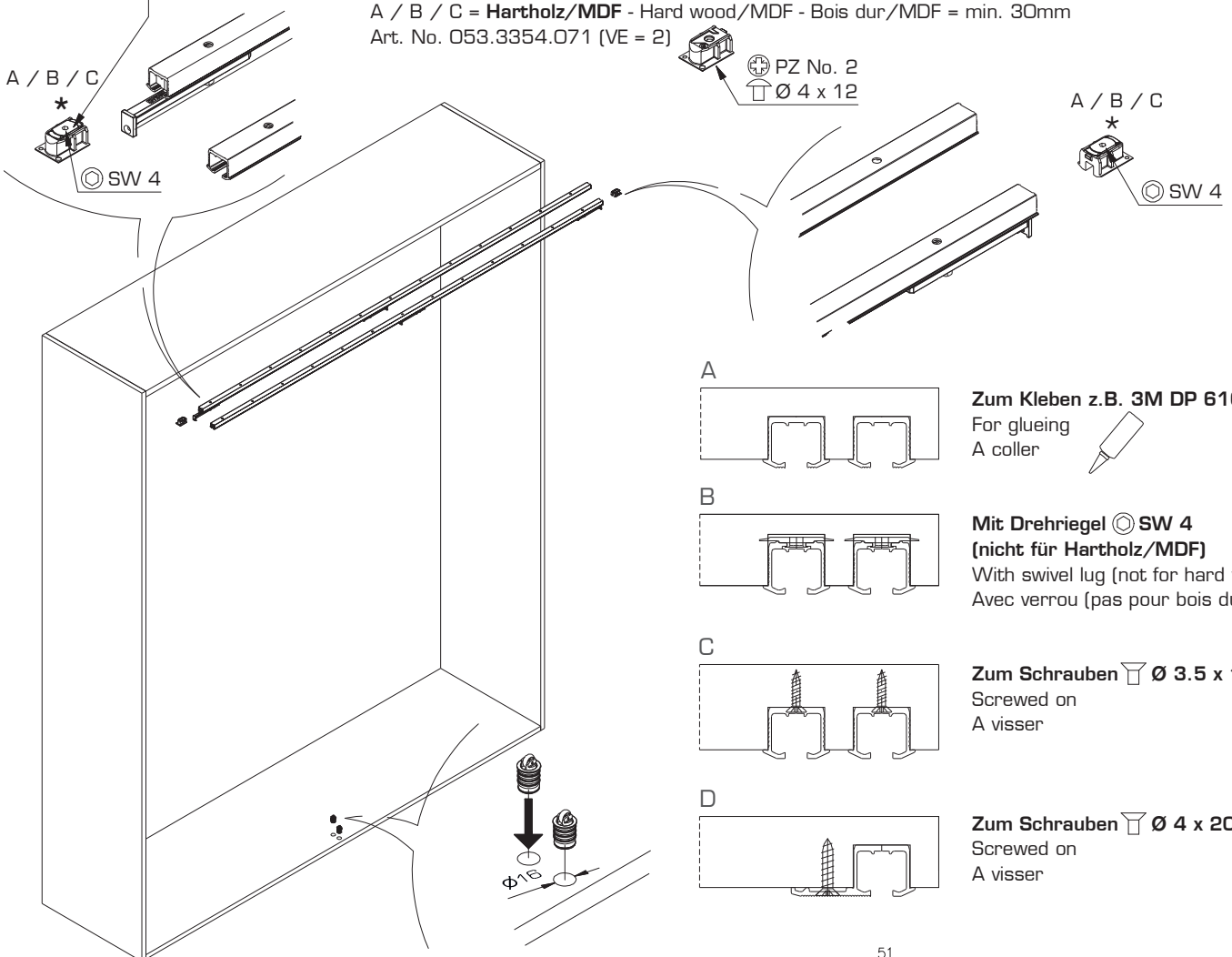

I

Schienenreiniger
Track cleaner
Nettoyant pour rails

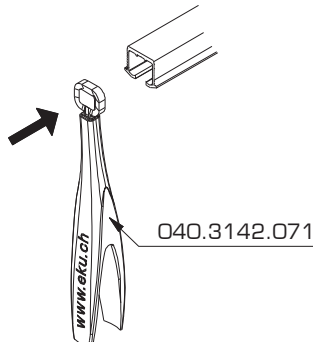

J

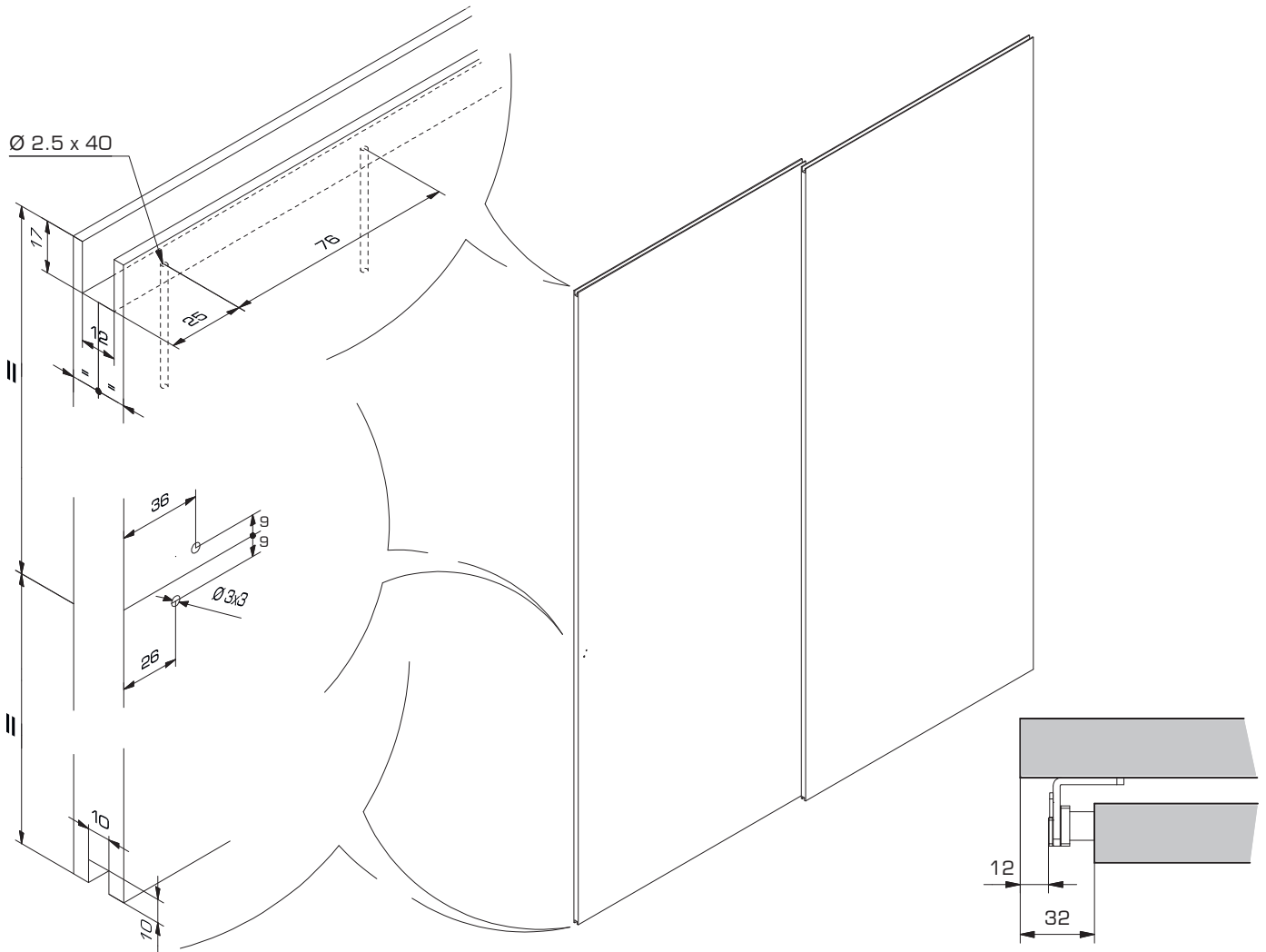

K

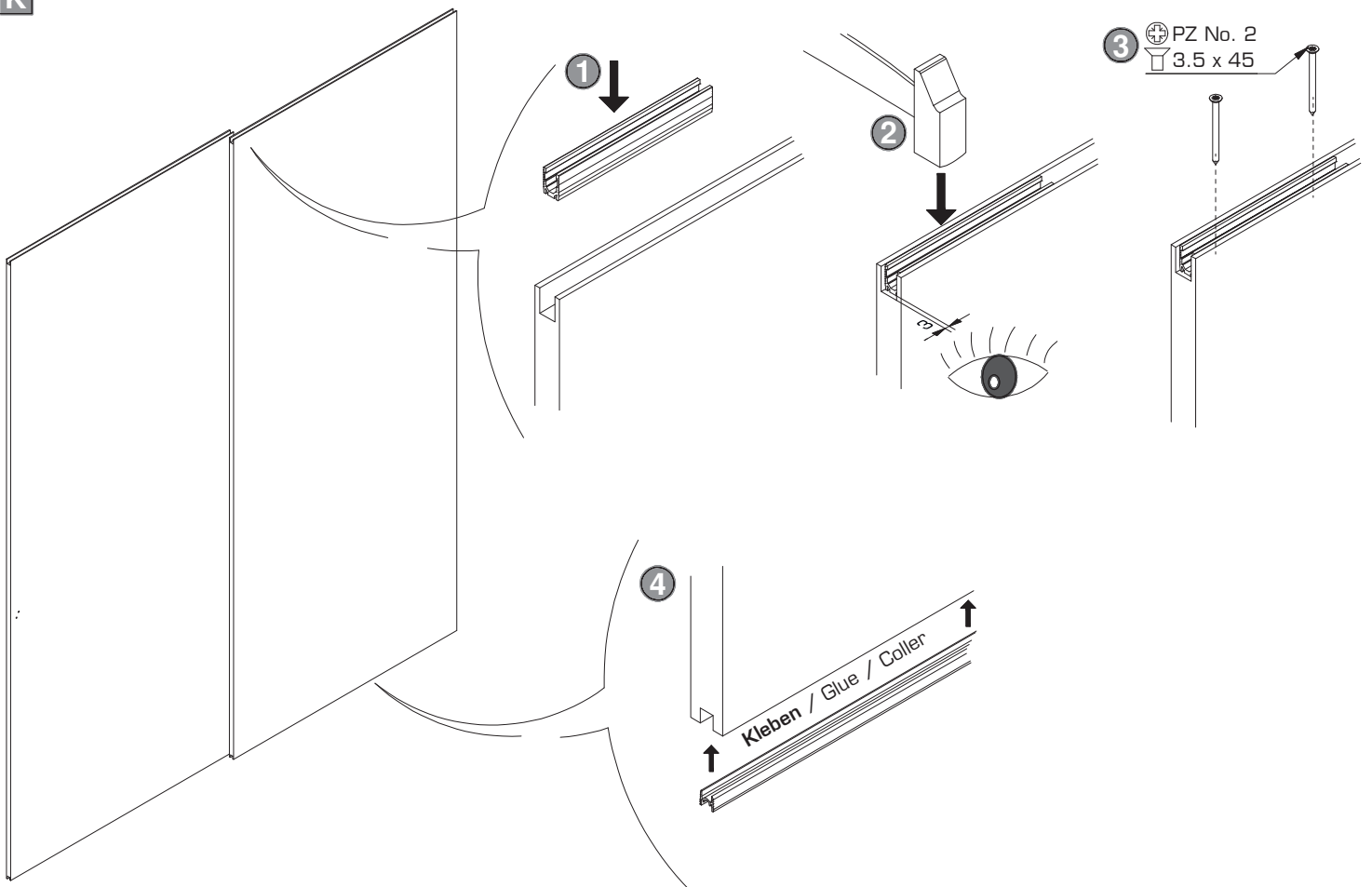

M

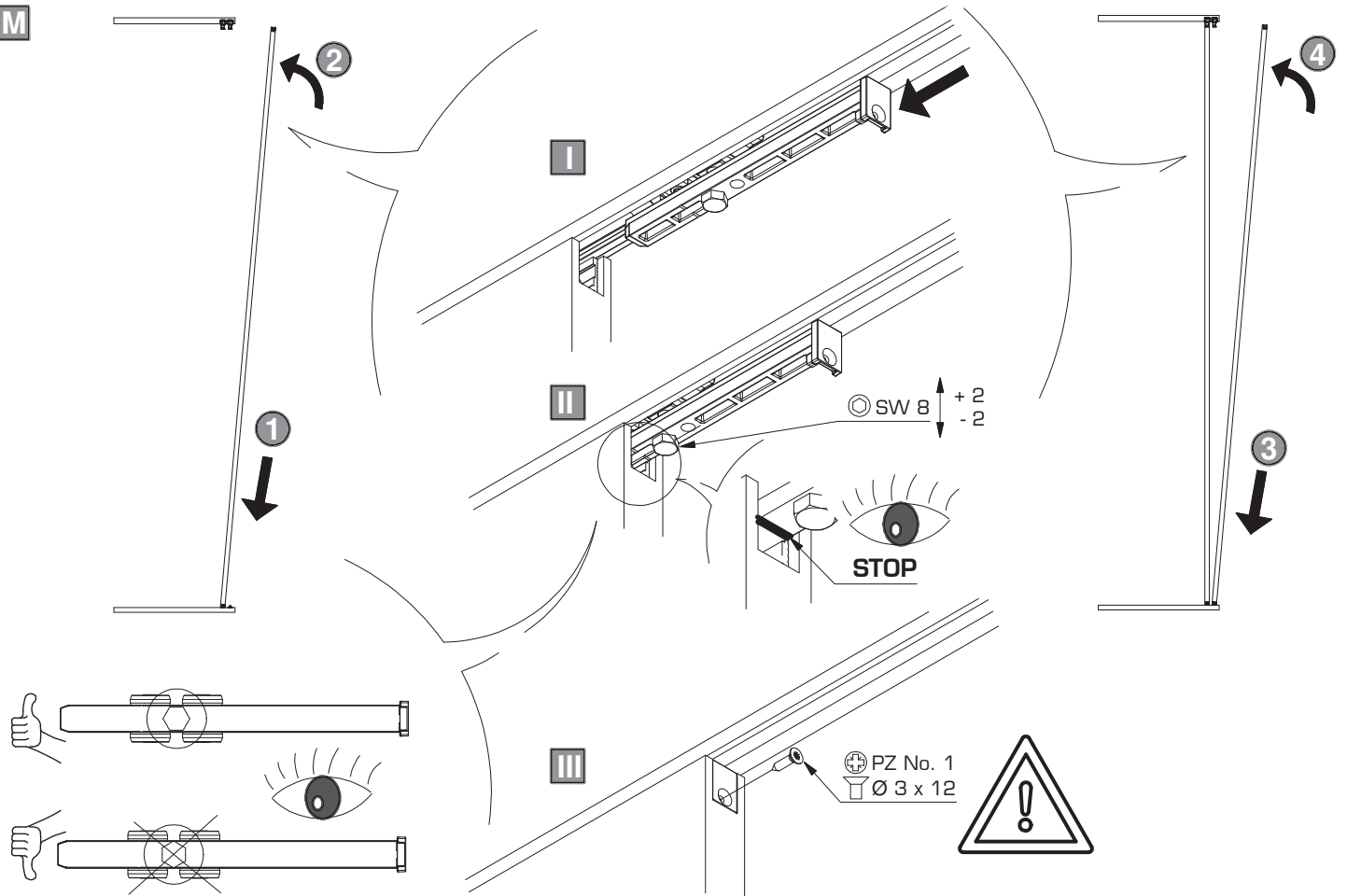

N

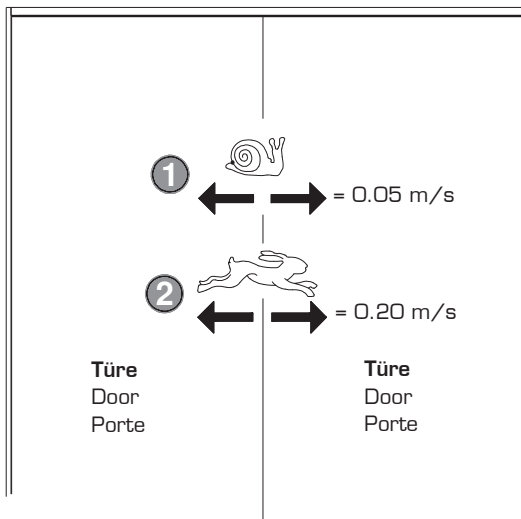

O

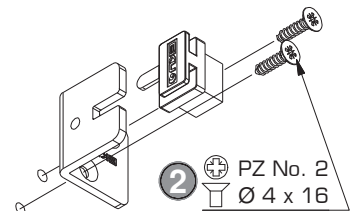
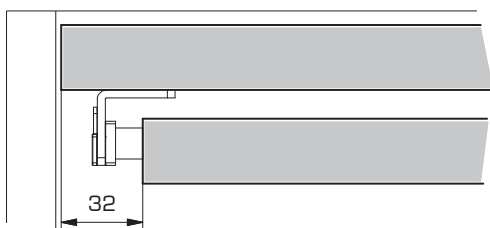
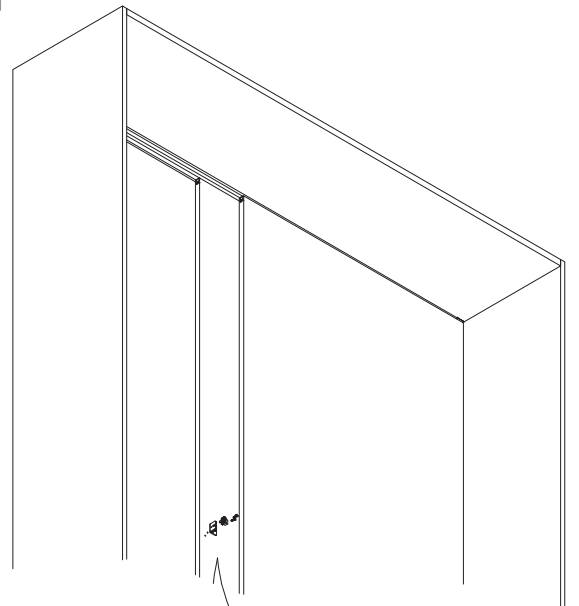

P Türdemontage
Door dismounting
Demontage de la porte

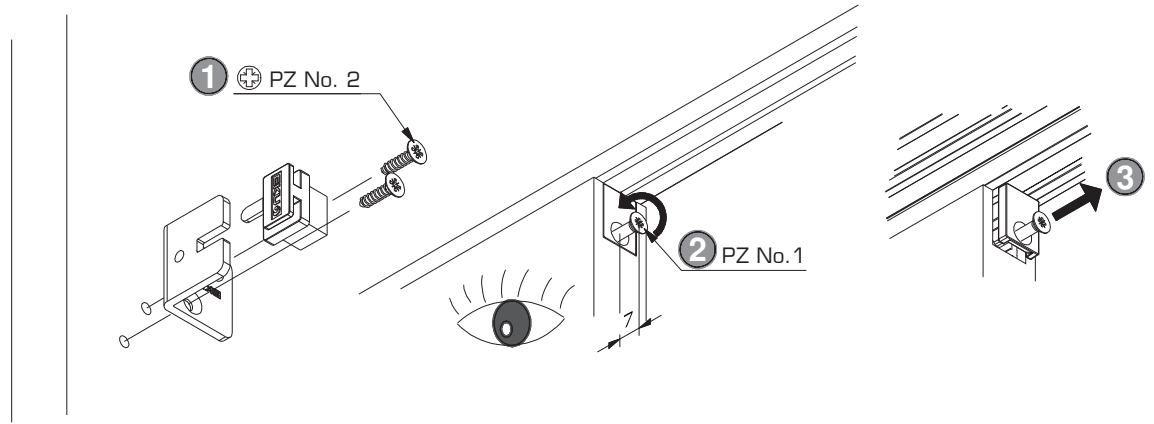

Einbaubeispiele/Mounting examples/Exemples de montage

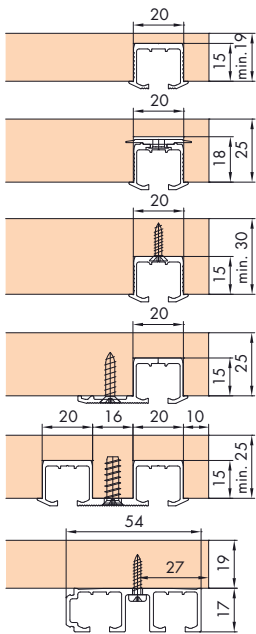

- A zum Kleben**
for glue fixing
à coller
- B mit Drehriegel (nicht für Hartholz/MDF)**
with swivel lug (not for hard wood/MDF)
avec verrou (pas pour bois dur/MDF)
- C zum Schrauben**
for screw fixing
à visser
- D zum Schrauben**
for screw fixing
à visser
- E zum Schrauben (nur für 25mm Türen)**
for screw fixing (25mm doors only)
à visser (seulement pour portes 25mm)
- F zum Aufschrauben (nur für 19mm Türen)**
for surface mounting with screws (19mm doors only)
à visser en applique (seulement pour portes 19mm)

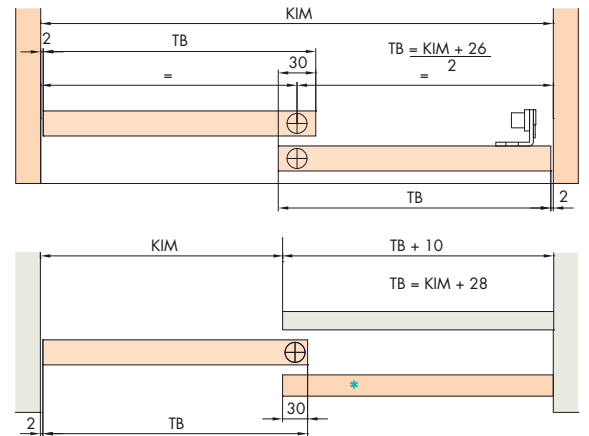

*Demontierbar/Removable/Démontable

